

AutoCUT 500

Automatic edge processing for weld preparation – simple and secure handling with guide rails on both sides.

AutoCUT 500 – This BDS machine is perfectly suited for straightforward and quick weld preparation. The system is characterised by easy handling and evenly milled sides for a perfect weld.

Bevel edge milling with automated and continually adjustable speed rate: fast, flexible and variable milling angle adjustment.

The guide rails make handling the AutoCUT 500 especially simple and secure. The milling angle can be continuously adjusted from 15 to 60°.

Advantages of the BDS AutoCUT 500

- ▶ Easy, safe handling
- ▶ No restrictions of the working length
- ▶ Work without carriage, i.e., independent of floor conditions
- ▶ Cutting up to a plate thickness of 40 mm
- ▶ Face milling head with carbide reversible plates



The AutoCUT 500 with automatic forward and return

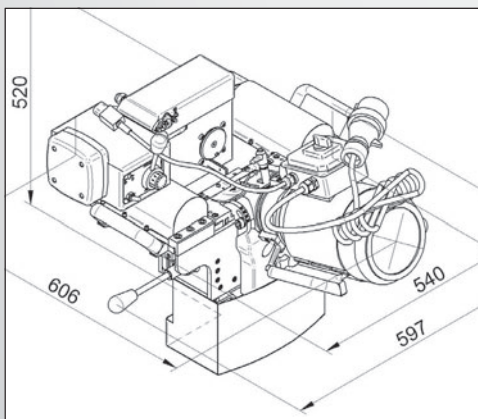

Technical drawing



AutoCUT 500 guide rails



Chamfer width 30 mm max.



Visit our homepage to experience
live the AutoCUT demo video.
[http://www.kernbohrer.de/downloads
/downloads.html#tab_4](http://www.kernbohrer.de/downloads/downloads.html#tab_4)



The advantages of AutoCUT 500

- > Fully automatic – forward and return motion via guide rollers
- > Powerful – Milling up to a plate thickness of 40 mm, unlimited working length
- > Guided on the plate, independent of floor conditions

SPECIFICATION

	Motor output:	1.1 kW
	Voltage:	380 V
	Weight:	50 kg
	Feed:	Automatic, continuously adjustable up to a maximum of 500 mm/min
	Speed range 1:	2750 min ⁻¹
	Chamfer width:	max. 30 mm
	Angle adjustment:	15 – 60° continuously
	Milling cutter:	Arbor milling cutter with 6 sintered carbide reversible disks

ACCESSORIES

ORDER NO.

Arbor milling cutter
ZFR 500 1 pc.

Carbide reversible disks are not included in delivery. Please clearly order them as an extra.

Carbide reversible disks
SHM 400 1 pc.
SHM 400-E 1 pc.

1 set = 6 carbide reversible disks SHM 400



Arbor milling cutter ZFR 500



Carbide reversible disk SHM 400

ORDER NO.

AutoCUT 500 / 380 Volt

SCOPE OF DELIVERY

1 AutoCUT 500	1 Jaw spanner M 19
1 Arbor milling cutter with 6 carbide reversible disks SHM 400	1 Screwdriver with T-handle SW 5
1 Operating manual	1 Offset screwdriver SW 6, SW 8, SW 10 each
1 Guide rail on both left and right side	1 Screwdriver TX 15