

EKF 300.3 – EKF 450.3 – EKF 452.3

Deburring and chamfering machines for quick and precise edge processing 20°, 45° or R 2.5 mm.

Deburring and chamfering with machines from the EKF series. The BDS deburring and chamfering machine can be universally used for industry and craft: In mould making, boiler construction, plant construction, mechanical engineering and for sheet metal working.

The EKF machine is ideally suited for deburring and chamfering of parts made of steel, stainless steel, non-ferrous metals, brass and plastic. Due to its handy, compact design, the machine can be used on straight edges, internal and external radii and for drill holes from \varnothing 22 mm. The fine adjustment allows slight chamfers for deburring up to the preparation of welding seams.



Three milling cutters with a chamfering angle of 45°, optionally 30° or a radius of 2.5 mm are available.

The reversible disks can be used in 3 ways. Due to the small guiding roller, insertion into drill holes from \varnothing 22 mm is possible without any problems.

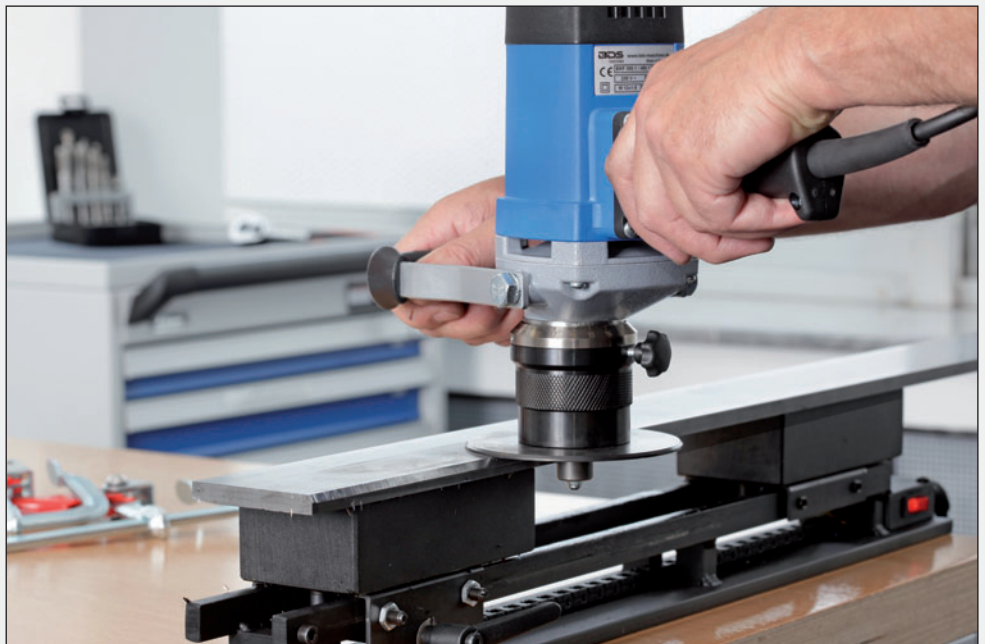

Edge processing with the EKF - the workpiece is securely fixed with the MagnetCLAMP magnetic clamping device. See page 79.

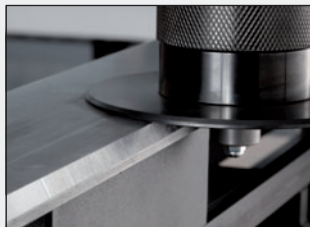
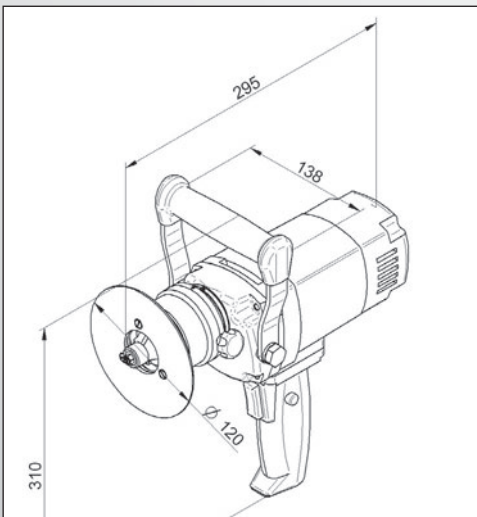

Cutting angle
30°



EKF 300.3 with milling cutter ZFR

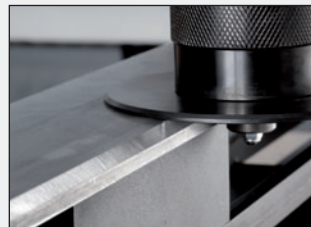

Cutting angle
45°



EKF 450.3 with milling cutter ZFR 450.3

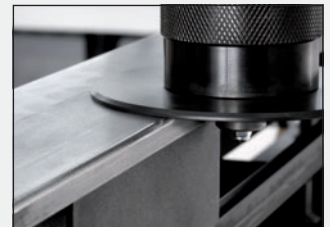

Radius
R 2.5 mm



EKF 452.3 with milling cutter ZFR 452.3









Visit our homepage to experience live the EKF demo video.
http://www.kernbohrer.de/downloads/downloads.html#tab_4



The advantages of the EKF

- > Straightforward – easy handling, low weight
- > Variable – 3 milling cutters optionally 45°, 30°, or R 2.5 mm
- > Powerful – 1.5 kW motor

SPECIFICATION

	Motor output:	1500 Watt
	Voltage:	220 - 240 V AC, 50-60 Hz
	Speed range 1:	6000 min ⁻¹
	Feed:	manual
	Milling cutter optional:	Fase 45° – width continuously 0 - 6 mm Fase 30° – width continuously 0 - 5 mm Radius R 2.5 mm
	Carbide reversible disks:	3 per milling cutter
	Weight:	4.6 kg

ACCESSORIES

ORDER NO.

Milling cutter

ZFR 300.3 – 30°

ZFR 450.3 – 45°

ZFR 452.3 – R 2.5

Carbide reversible disks are not included in delivery. Please clearly order them as an extra.

Carbide reversible disks

SHM 200 1 pc.

SHM 200-E 1 pc.

SHM 202 1 pc.

1 set = 3 carbide reversible disks SHM



Changeable carbide reversible

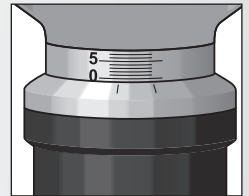

Fine adjustment

ORDER NO.

EKF 300.3 / 230 Volt

EKF 300.3 / 110 Volt

EKF 450.3 / 230 Volt

EKF 450.3 / 110 Volt

EKF 452.3 / 230 Volt

EKF 452.3 / 110 Volt

SCOPE OF DELIVERY

1 Deburring and chamfering machine

1 Milling cutter

3 Carbide reversible disks

1 Jaw spanner SW 22

1 Carry case

1 Sickle spanner

1 Torx screwdriver T9

1 Operating manual