



TIG - With or without Filler Wire, AVC, OSC

Open Welding Head

for welding of tube to tube joints,
tube to elbow joints...



MU IV Open Welding Head

for welding of tube to tube joints, tube to elbow joints...

A range of modular standard welding heads, perfectly adapted to your needs

General Characteristics

Advantages

- ▶ Productivity increase of more than one third
- ▶ Easy to use
- ▶ Challenging applications, even with delicate materials, can be welded
- ▶ Quick to set-up according to the workload making variations in production capacity trouble free
- ▶ Precision engineered assemblies for a lifetime of trouble-free service

Resulting from 50 years' experience in mastering welding technologies

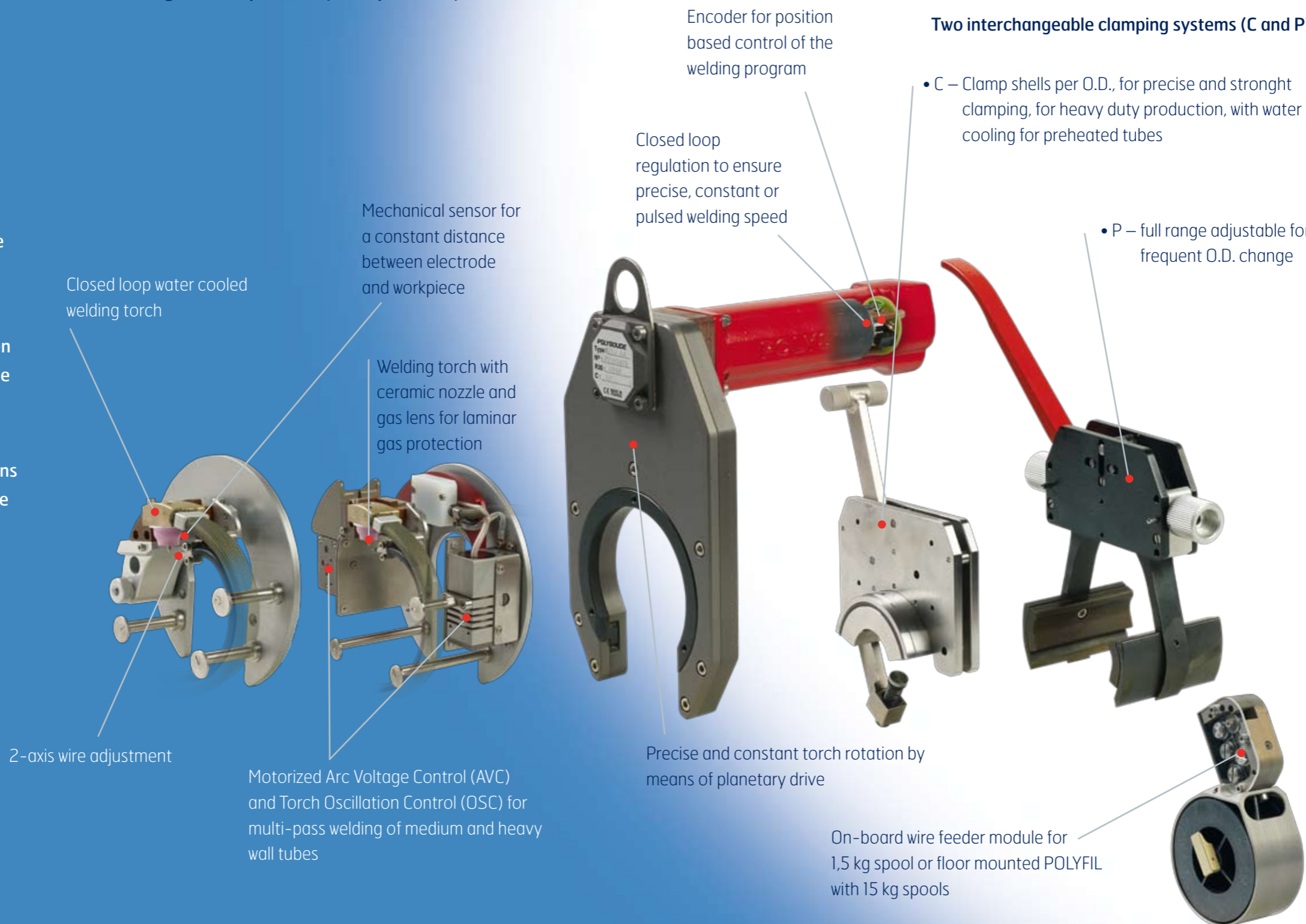

MU IV for use with external wire feeder

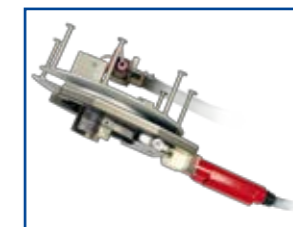

Drive motor with angle gearbox for reduced axial clearance



MU IV with integrated wire feeder



MU IV with AVC/OSC

Associated Power Sources



▶ PS 164-2

160 A, "all inclusive", portable, single-phase power supply



▶ P4

170 A, "modular", portable, programming by PC or touch screen, single-phase power supply



▶ PS 406-2

400 A, "all inclusive", with Arc Voltage Control (AVC) and Torch Oscillation Control (OSC), three-phase power supply



▶ P6

300 A, "all applications", programming by PC or touch screen, with Arc Voltage Control (AVC) and Torch Oscillation Control (OSC), three-phase power supply

Wire Feeder



▶ Polyfil-3

External wire feeder and other integrated wire feeders

Technical Specification

Cable length: 9 m

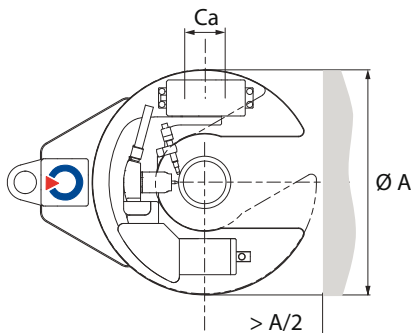
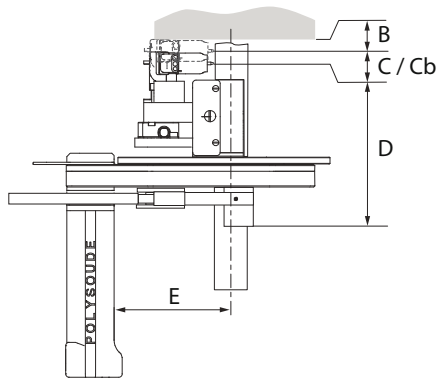

* on request

P – Adjustable clamping system

C – Adjustable clamping system

		Type	Dimensions in mm					
O.D. independent adjustable clamping	MU IV Min. Ø / Max. Ø	Double clamping system recommended	Ø A	B	C	D	E	
	MU IV 14/28 P *	/	116	16	5	96	70	
	MU IV 8/38 P	/	126	16	5	96	72	
	MU IV 19/64 P *	/	155	16	5	98	93	
	MU IV 19/80 P	/	172	16	5	97	103	
	MU IV 19/104 P *	/	204	16	5	90	121,5	
	MU IV 25/115 P	/	215	16	5	101	148	
	MU IV 25/128 P *	/	240	16	5	99	173	
	MU IV 76/195 P	/	410	30,5	14	158,5	208	
	MU IV 101/245 P *	/	470	30,5	14	174,5	254	
	MU IV 114/275 P	/	500	30,5	14	172,5	276	
O.D. related shell clamping	MU IV 14/28 C *	Ø 8 to 28	116	16	5	79	70	
	MU IV 14/38 C *	Ø 8 to 38	126	16	5	79	72	
	MU IV 30/64 C *	Ø 19 to 64	155	16	5	88	93	
	MU IV 30/80 C *	Ø 19 to 80	172	16	5	88	103	
	MU IV 44/104 C *	Ø 19 to 104	204	16	5	90	121,5	
	MU IV 50/115 C *	Ø 25 to 115	215	16	5	92	148	
	MU IV 50/128 C *	Ø 25 to 128	240	16	5	108	173	
	MU IV 76/195 C *	/	410	30,5	14	178	208	
	MU IV 101/245 C *	/	470	30,5	14	180	254	
	MU IV 114/275 C *	/	500	30,5	14	178,5	276	
	O.D. independent adjustable clamping	MU IV AVC, OSC Min. Ø / Max. Ø	Double clamping system recommended	Ø A	B	Amplitude		D
MU IV 8/38 P		/	142	23	Ca	Cb	150	72
MU IV 19/64 P *		/	184	16	20	20	136	93
MU IV 19/80 P		/	200	16	20	20	136	103
MU IV 30/104 P *		/	222	16	20	20	140	121,5
MU IV 42/115 P		/	235	16	20	20	139	148
MU IV 42/128 P *		/	340	16	20	30	134	173
MU IV 76/195 P		/	410	16	20	30	165	208
MU IV 101/245 P *		/	500	16	20	30	179	254
MU IV 114/275 P		/	530	16	20	30	179	276
O.D. related shell clamping		MU IV 14/38 C *	Ø 8 to 38	142	23	20	20	130
	MU IV 30/64 C *	Ø 19 to 64	184	16	20	20	128	93
	MU IV 30/80 C *	Ø 19 to 80	200	16	20	20	126	103
	MU IV 44/104 C *	/	222	16	20	20	128	124,5
	MU IV 50/115 C *	/	235	16	20	20	128	148
	MU IV 50/128 C *	Ø 25 to 128	340	16	20	30	143	173
	MU IV 76/195 C *	/	410	16	20	30	185	208
MU IV 101/245 C *	/	500	16	20	30	184	254	
MU IV 114/275 C *	/	530	16	20	30	184	276	

Options and Accessories

- On board wire feeder module for 1,5 kg spool or floor mounted POLYFIL with 15 kg spools
- Clamp shells (C-clamping system) for all tube and pipe O.D.'s
- Extension cable (15 m)
- Dual welding head switch box
- Compact brief-case for transport and storage
- Tungsten electrodes, pre-sharpened and pre-cut

 Adapting to all your applications!



"As working conditions are better than in manual welding, a welding operator accomplishes on average 30% more welds per day."

POLYSOUDE : Related Services

► Guidance and technical support

A welding application specialist in your area will advise you on the welding process and appropriate equipment for your application.

► Commissioning / Training

A complete training program will enable you to start using the equipment immediately and in the best way possible.

► Maintenance / Repair

Maintenance and repair operations can be carried out at the Polysoude plant as well as on site by our service network.

► Rental service

Increase the flexibility of your production! A large range of equipment is available for rental from our hire fleet.

Your partners worldwide

AUSTRALIA

POLYSOUDE S.A.S.
☎ +33 (0) 2 40 68 11 00
info@polysoude.com

AUSTRIA

POLYSOUDE AUSTRIA GmbH
☎ +43 (0) 3613 200 36
austria@polysoude.at

BELGIUM

POLYSOUDE BENELUX
☎ +31 (0) 653 84 23 36
k.meurs@polysoude.com

POLYSOUDE BENELUX

(SERVICE)
☎ +31 (0) 653 38 85 58
h.milder@polysoude.com

BRAZIL

**AJADE COMÉRCIO INSTALAÇÕES
E SERVIÇOS Ltda.**
☎ +55 (0) 11 45 24 38 98
fernando@ajade.com.br

BULGARIA

KARWELD FOOD
☎ +359 (0) 29 73 32 15
Karweld@bg400.bg

CANADA

MAG TOOL Inc.
EDMONTON - ALBERTA
☎ 800 661 9983
magtool@magtool.com

MAG TOOL Inc.

CAMBRIDGE - ONTARIO
☎ +1 519 651 10 50
michael@magtool.com

CHINA

POLYSOUDE SHANGHAI CO. Ltd
☎ +86 (0) 21 64 09 78 26
j.zhang@polysoude.cn

CROATIA

EUROARC D.O.O.
☎ +385 (0) 1 2 40 60 77
euroarc@euroarc.hr

CZECH REPUBLIC

POLYSOUDE CZ
☎ +420 602 60 28 55
m.matousek@polysoude.cz

DENMARK

POLYSOUDE DENMARK
☎ +45 (0) 32 94 85 10
orbital@polysoude.dk

EGYPT

POLYSOUDE UK
☎ +44 (0) 1942 820 935
info@polysoude.com

ESTONIA

POLYSOUDE S.A.S.
☎ +33 (0) 2 40 68 11 00
info@polysoude.com

FINLAND

SUOMEN TEKNOHAUS OY
☎ +358 (0) 927 47 2 10
info@teknohaus.fi

FRANCE

POLYSOUDE S.A.S.
☎ +33 (0) 2 40 68 11 00
info@polysoude.com

GERMANY

**POLYSOUDE DEUTSCHLAND
KORNWESTHEIM**
☎ +49 (0) 7154 1796 90
info@polysoude.com

POLYSOUDE DEUTSCHLAND

LEVERKUSEN / OPLADEN
☎ +49 (0) 7154 1796 90
info@polysoude.com

ITALY

POLYSOUDE ITALIA SRL
☎ +39 (0) 2 93 79 90 94
b.baccegga@polysoude.it

JAPAN

GMT CO Ltd - KAWASAKI
☎ +81 (0) 44 222 6751
gmt@e-gmt.co.jp

GMT CO Ltd - OSAKA

☎ +81 (0) 789 35 6751
gmt.kansai@e-gmt.co.jp

JORDAN

POLYSOUDE UK
☎ +44 (0) 1942 820 935
info@polysoude.com

NEW ZEALAND

POLYSOUDE S.A.S.
☎ +33 (0) 2 40 68 11 00
info@polysoude.com

NORWAY

POLYSOUDE BENELUX
☎ +31 (0) 653 84 23 36
k.meurs@polysoude.com

PAKISTAN

POLYSOUDE S.A.S.
☎ +33 (0) 2 40 68 11 00
info@polysoude.com

PHILIPPINES

POLYSOUDE ASIA
☎ +86 (0) 65 862 60 08
Jmpan@singnet.com.sg

SINGAPORE

POLYSOUDE ASIA
☎ +86 (0) 65 68 62 60 08
Jmpan@singnet.com.sg

SIN SOON HUAT WELDING

PRODUCTS PTE. Ltd
☎ +65 (0) 62 65 60 88
wchng@sshcorp.com

SLOVAKIA

CHEMIKO CO Ltd
☎ +420 602 60 28 55
m.matousek@polysoude.cz

SOUTH AFRICA

POLYSOUDE S.A.S.
☎ +33 (0) 2 40 68 11 00
info@polysoude.com

SOUTH KOREA

CHEMIKO CO Ltd
☎ +82 (0) 2 567 5336
chemiko@chol.com

SPAIN

PRAXAIR SOLDADURA S.L.
☎ +34 (0) 91 78 55 77 09
Luis_Alfredo_de_Andres@praxair.com

SWEDEN

POLYSOUDE BENELUX
☎ +31 (0) 653 84 23 36
k.meurs@polysoude.com

SWITZERLAND

POLYSOUDE (SWITZERLAND) Inc.
☎ +41 (0) 43 243 50 80
contact@polysoude.ch

TAIWAN R.O.C.

FIRST ELITE ENT. CO. Ltd
☎ +886 (0) 287 97 88 99
auto.pipe@msa.hinet.net

THAILAND

POLYSOUDE ASIA
☎ +86 (0) 65 6862 60 08
Jmpan@singnet.com.sg

TURKEY

POLYSOUDE S.A.S.
☎ +33 (0) 2 40 68 11 00
info@polysoude.com

UNITED ARAB EMIRATES

GERMAN GULF ENTERPRISES Ltd
☎ +971 (0) 65 31 61 71
info@polysoude.com

UKRAINE

POLYSOUDE RUSSIA
☎ +7 (0) 495 564 86 81
polysoude@co.ru

UNITED STATES

ASTRO ARC POLYSOUDE Inc.
☎ +1 (0) 661 702 01 41
sales@astroarc.com

VENEZUELA

ENRIVA C.A.
☎ +58 (0) 243 242 45 41
enriva@cantv.net



LATVIA

POLYSOUDE S.A.S.
☎ +33 (0) 2 40 68 11 00
info@polysoude.com

LITHUANIA

POLYSOUDE S.A.S.
☎ +33 (0) 2 40 68 11 00
info@polysoude.com

MALAYSIA

POLYSOUDE ASIA
☎ +86 (0) 65 862 60 08
Jmpan@singnet.com.sg

MEXICO

ASTRO ARC POLYSOUDE Inc.
☎ +1 (0) 661 702 01 41
sales@astroarc.com

NETHERLANDS

POLYSOUDE BENELUX
☎ +31 (0) 653 84 23 36
k.meurs@polysoude.com

POLYSOUDE BENELUX

(SERVICE)
☎ +31 (0) 653 38 85 58
h.milder@polysoude.com

POLAND

TEFROMES Sp. z o.o. - IMIELIN
☎ +48 (0) 32 225 62 77
biuro@tefromes.com.pl

UNIDAWELD - BEDZIN

☎ +48 (0) 32 267 05 54
dariusz.szota@unidaweld.pl

ZALCO Sp. z o.o. - WARSZAWA

☎ +48 (0) 22 894 55 30
mbergman@zalco.pl

PORTUGAL

PRAXAIR SOLDADURA S.L.
☎ +34 (0) 91 453 30 00
Luis_Alfredo_de_Andres@praxair.com

ROMANIA

DEBISUD S.R.L.
☎ +40 (0) 255 21 57 85
debisud@rdslink.ro

RUSSIA + C.I.S.

POLYSOUDE RUSSIA
☎ +7 495 564 86 81
polysoude@co.ru

SAUDI ARABIA

ALRUQUEE MACHINE TOOLS
☎ +966 (0) 385 7 63 87
2HCoordinator1.Peiris@alruqee.com