

TS 34

TIG - Without Filler Wire

Closed Chamber Welding Head
for welding of tube to tubesheet joints

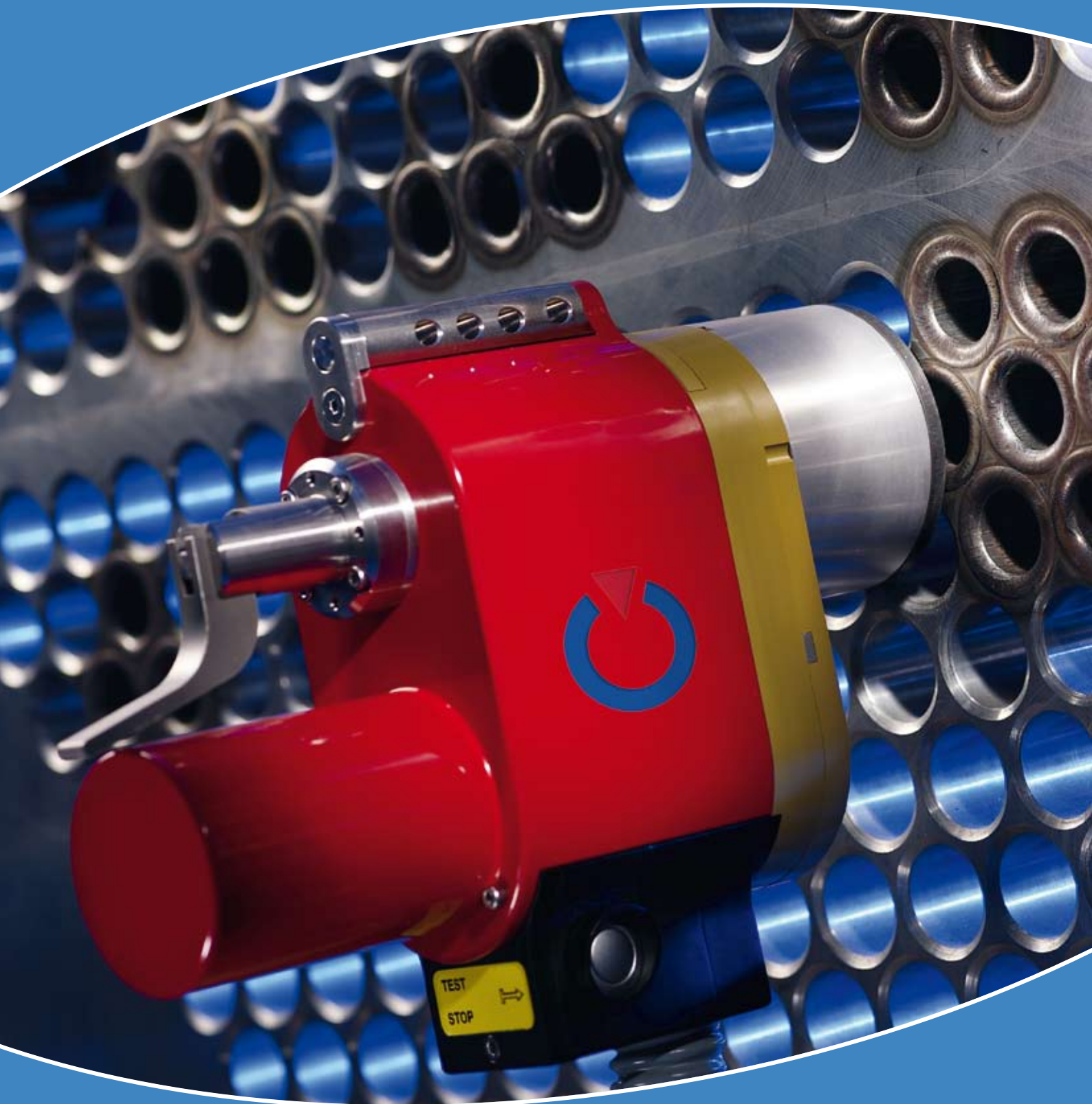

TS 34 Closed Chamber Welding Head

for welding of tube to tubesheet joints

Easy to use, highest quality and productivity

General Characteristics

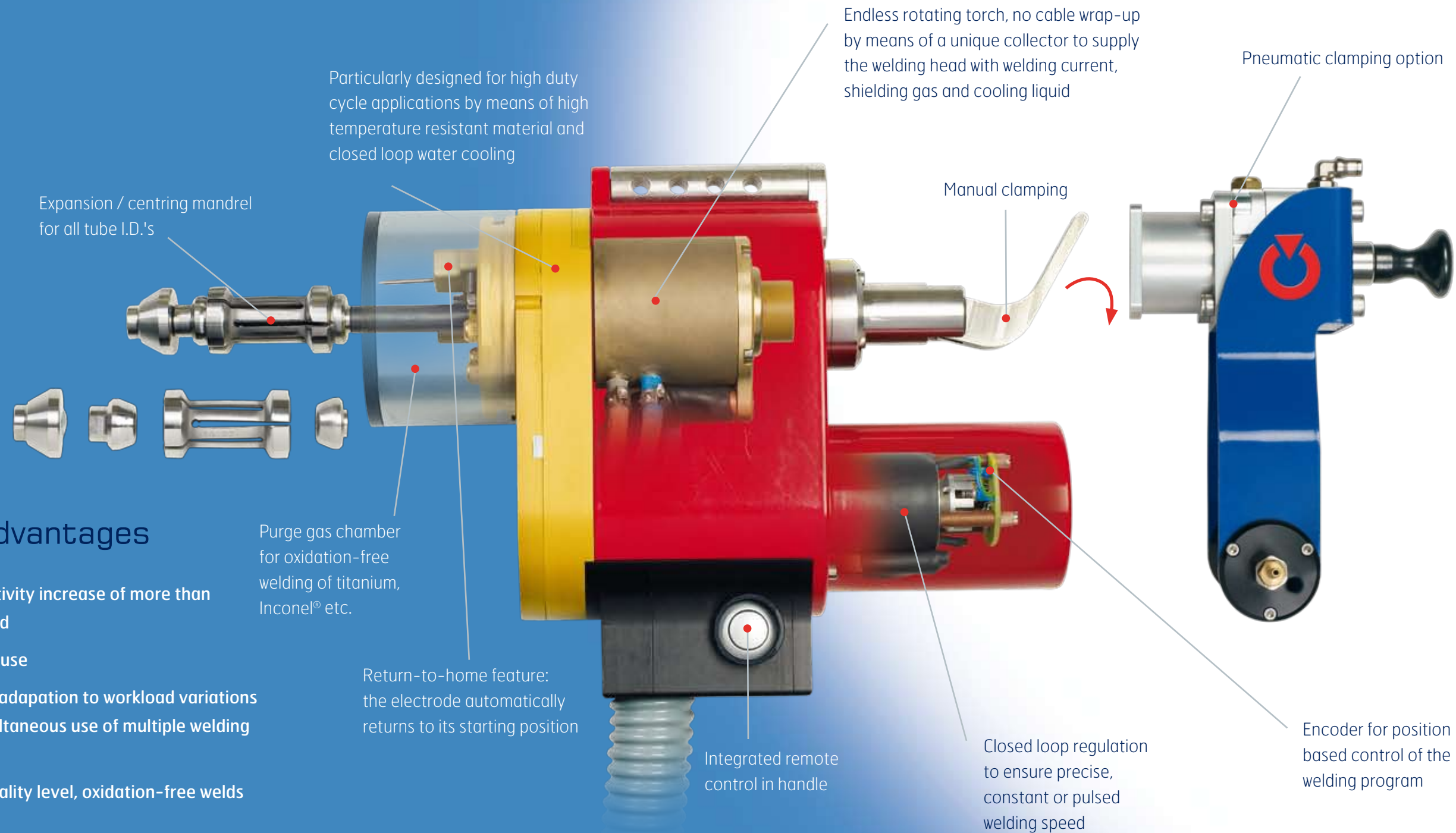

Laminar diffusion of the protection gas inside the purge gas chamber

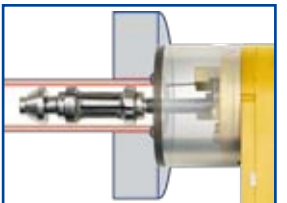

Flush tube welding (purge gas chamber)

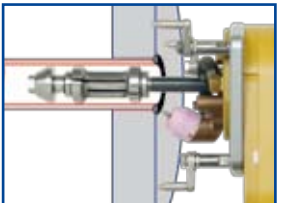

Flush tube welding (torch with diffuser)

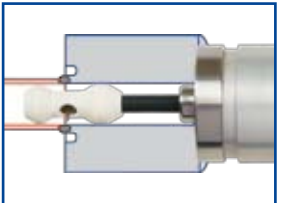

Back plate tube welding



Nipple on header

Advantages

- ▶ Productivity increase of more than one third
- ▶ Easy to use
- ▶ Instant adaptation to workload variations by simultaneous use of multiple welding heads
- ▶ High quality level, oxidation-free welds

Resulting from 50 years' experience in mastering welding technologies

Associated Power Sources



▶ PS 164-2

160 A, "all inclusive", portable, single-phase power supply



▶ P4

170 A, "modular", portable, programming by PC or touch screen, single-phase power supply



▶ P6

300 A, "all applications", programming by PC or touch screen, with Arc Voltage Control (AVC) and Torch Oscillation Control (OSC), three-phase power supply

Technical Specification

Min. tube I.D.	10 mm
Max. tube O.D.	33,7 mm
	for other dimensions, please consult us
Duty cycle	120 A max 120 A / 75 %
Torch cooling	Closed loop, water
Tube joint designs:	
• flush	✓
• recessed	1 mm max
• protruding	0,5 mm max
• internal bore welding	✓
Positioning / centring	Expansion mandrel
Purge gas chamber	✓
Weight	3,8 kg (excl. cable)

✓ standard
✓ option

Cable length: 9 m

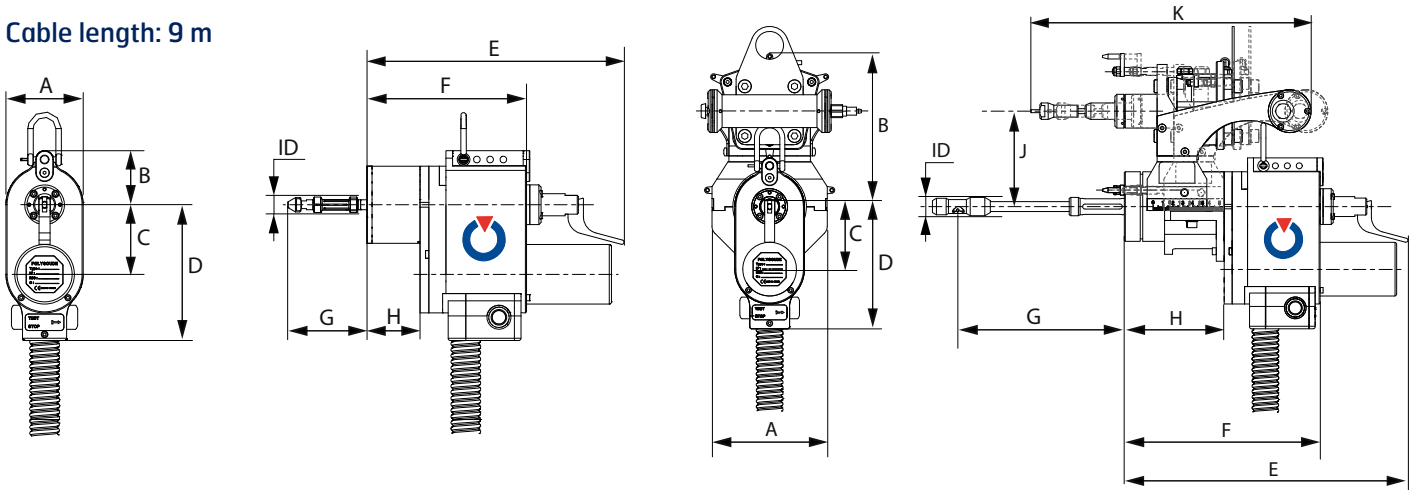

Dimensions in mm

	A	B	C	D	E	F	G	H	IDmin	IDmax	J	K
TS 34	70	49	63	123	235	144,5	80	48	9,5	32		
TS 34 + Pneumatic clamping system	116	154	63	123	285	197	According to application	100,5	12	28	96	273

Options and Accessories

- Expansion / centring mandrels for all tube I.D.'s
- Pneumatic expansion / centring device
- Dual welding head switch box
- Compact brief-case for packing, transport and storage
- Tool kit for daily operation
- Extension cable (15 m)
- Tungsten electrodes, pre-sharpened and pre-cut

 Adapting to all your applications!



*"On our site, an operator uses
2 or 3 welding heads simultaneously."*

POLYSOUDE : Related Services

► Guidance and technical support

A welding application specialist in your area will advise you on the welding process and appropriate equipment for your application.

► Commissioning / Training

A complete training program will enable you to start using the equipment immediately and in the best way possible.

► Maintenance / Repair

Maintenance and repair operations can be carried out at the Polysoude plant as well as on site by our service network.

► Rental service

Increase the flexibility of your production! A large range of equipment is available for rental from our hire fleet.

Your partners worldwide

AUSTRALIA

POLYSOUDE S.A.S.
☎ +33 (0) 2 40 68 11 00
info@polysoude.com

AUSTRIA

POLYSOUDE AUSTRIA GmbH
☎ +43 (0) 3613 200 36
austria@polysoude.at

BELGIUM

POLYSOUDE BENELUX
☎ +31 (0) 653 84 23 36
k.meurs@polysoude.com

POLYSOUDE BENELUX

(SERVICE)
☎ +31 (0) 653 38 85 58
h.milder@polysoude.com

BRAZIL

AJADE COMÉRCIO INSTALAÇÕES E SERVIÇOS Ltda.
☎ +55 (0) 11 45 24 38 98
fernando@ajade.com.br

BULGARIA

KARWELD FOOD
☎ +359 (0) 29 73 32 15
Karweld@bg400.bg

CANADA

MAG TOOL Inc.
EDMONTON - ALBERTA
☎ 800 661 9983
magtool@magtool.com

MAG TOOL Inc.

CAMBRIDGE - ONTARIO
☎ +1 519 651 10 50
michael@magtool.com

CHINA

POLYSOUDE SHANGHAI CO. Ltd
☎ +86 (0) 21 64 09 78 26
j.zhang@polysoude.cn

CROATIA

EUROARC D.O.O.
☎ +385 (0) 1 2 40 60 77
euroarc@euroarc.hr

CZECH REPUBLIC

POLYSOUDE CZ
☎ +420 602 60 28 55
m.matousek@polysoude.cz

DENMARK

POLYSOUDE DENMARK
☎ +45 (0) 32 94 85 10
orbital@polysoude.dk

EGYPT

POLYSOUDE UK
☎ +44 (0) 1942 820 935
info@polysoude.com

ESTONIA

POLYSOUDE S.A.S.
☎ +33 (0) 2 40 68 11 00
info@polysoude.com

FINLAND

SUOMEN TEKNOHAUS OY
☎ +358 (0) 927 47 2 10
info@teknohaus.fi

FRANCE

POLYSOUDE S.A.S.
☎ +33 (0) 2 40 68 11 00
info@polysoude.com

GERMANY

POLYSOUDE DEUTSCHLAND KORNWESTHEIM
☎ +49 (0) 7154 1796 90
info@polysoude.com

POLYSOUDE DEUTSCHLAND LEVERKUSEN / OPLADEN

☎ +49 (0) 7154 1796 90
info@polysoude.com

ITALY

POLYSOUDE ITALIA SRL
☎ +39 (0) 2 93 79 90 94
b.baccegga@polysoude.it

JAPAN

GMT CO Ltd - KAWASAKI
☎ +81 (0) 44 222 6751
gmt@e-gmt.co.jp

GMT CO Ltd - OSAKA

☎ +81 (0) 789 35 6751
gmt.kansai@e-gmt.co.jp

JORDAN

POLYSOUDE UK
☎ +44 (0) 1942 820 935
info@polysoude.com

NEW ZEALAND

POLYSOUDE S.A.S.
☎ +33 (0) 2 40 68 11 00
info@polysoude.com

NORWAY

POLYSOUDE BENELUX
☎ +31 (0) 653 84 23 36
k.meurs@polysoude.com

PAKISTAN

POLYSOUDE S.A.S.
☎ +33 (0) 2 40 68 11 00
info@polysoude.com

PHILIPPINES

POLYSOUDE ASIA
☎ +86 (0) 65 862 60 08
Jmpan@singnet.com.sg

SINGAPORE

POLYSOUDE ASIA
☎ +86 (0) 65 68 62 60 08
Jmpan@singnet.com.sg

SIN SOON HUAT WELDING PRODUCTS PTE. Ltd

☎ +65 (0) 62 65 60 88
wchng@sshcorp.com

SLOVAKIA

CHEMIKO CZ
☎ +420 602 60 28 55
m.matousek@polysoude.cz

SOUTH AFRICA

CHEMIKO S.A.S.
☎ +33 (0) 2 40 68 11 00
info@polysoude.com

SOUTH KOREA

CHEMIKO CO Ltd
☎ +82 (0) 2 567 5336
chemiko@chol.com

SPAIN

PRAXAIR SOLDADURA S.L.
☎ +34 (0) 91 78 55 77 09
Luis_Alfredo_de_Andres@praxair.com

SWEDEN

POLYSOUDE BENELUX
☎ +31 (0) 653 84 23 36
k.meurs@polysoude.com

SWITZERLAND

POLYSOUDE (SWITZERLAND) Inc.
☎ +41 (0) 43 243 50 80
contact@polysoude.ch

TAIWAN R.O.C.

FIRST ELITE ENT. CO. Ltd
☎ +886 (0) 287 97 88 99
auto.pipe@msa.hinet.net

THAILAND

POLYSOUDE ASIA
☎ +86 (0) 65 6862 60 08
Jmpan@singnet.com.sg

TURKEY

POLYSOUDE S.A.S.
☎ +33 (0) 2 40 68 11 00
info@polysoude.com

UNITED ARAB EMIRATES

GERMAN GULF ENTERPRISES Ltd
☎ +971 (0) 65 31 61 71
info@polysoude.com

UKRAINE

POLYSOUDE RUSSIA
☎ +7 (0) 495 564 86 81
polysoude@co.ru

UNITED STATES

ASTRO ARC POLYSOUDE Inc.
☎ +1 (0) 661 702 01 41
sales@astroarc.com

VENEZUELA

ENRIVA C.A.
☎ +58 (0) 243 242 45 41
enriva@cantv.net



LATVIA

POLYSOUDE S.A.S.
☎ +33 (0) 2 40 68 11 00
info@polysoude.com

LITHUANIA

POLYSOUDE S.A.S.
☎ +33 (0) 2 40 68 11 00
info@polysoude.com

MALAYSIA

POLYSOUDE ASIA
☎ +86 (0) 65 862 60 08
Jmpan@singnet.com.sg

MEXICO

ASTRO ARC POLYSOUDE Inc.
☎ +1 (0) 661 702 01 41
sales@astroarc.com

NETHERLANDS

POLYSOUDE BENELUX
☎ +31 (0) 653 84 23 36
k.meurs@polysoude.com

POLYSOUDE BENELUX (SERVICE)

☎ +31 (0) 653 38 85 58
h.milder@polysoude.com

POLAND

TEFROMES Sp. z o.o. - IMIELIN
☎ +48 (0) 32 225 62 77
biuro@tefromes.com.pl

UNIDAWELD - BEDZIN

☎ +48 (0) 32 267 05 54
dariusz.szota@unidaweld.pl

ZALCO Sp. z o.o. - WARSZAWA

☎ +48 (0) 22 894 55 30
mbergman@zalco.pl

PORTUGAL

PRAXAIR SOLDADURA S.L.
☎ +34 (0) 91 453 30 00
Luis_Alfredo_de_Andres@praxair.com

ROMANIA

DEBISUD S.R.L.
☎ +40 (0) 255 21 57 85
debisud@rdslink.ro

RUSSIA + C.I.S.

POLYSOUDE RUSSIA
☎ +7 495 564 86 81
polysoude@co.ru

SAUDI ARABIA

ALRUQUEE MACHINE TOOLS
☎ +966 (0) 385 7 63 87
2HCordinator1.Peiris@alruqee.com