

K-BUG 2000

DIGITAL, COMPACT, DUAL TORCH FILLET WELDER

A magnetic travel carriage for welding continuous or stitch welds in the horizontal position.

Increase welding production, improve weld quality and eliminate operator fatigue.



Bug-O Systems

Automated Cutting and
Welding Systems.

Bug-O Systems is guided by honesty, integrity and ethics in service to our customers and in all we do.

412-331-1776

www.bug-o.com



K-BUG 2000 DIGITAL, COMPACT, DUAL TORCH FILLET WELDER

The **K-BUG 2000** digital, compact dual torch fillet welder is a portable straight line travel carriage. Creating two continuous or intermittent "stitch" welds at a constant travel speed the **K-BUG 2000** simultaneously produces high quality, uniform welds in a fraction of the time compared to manual welding. Regulated travel speed eliminates excessive weld deposition and helps reduce defects. The machine's guide wheels track the workpiece to provide precise, continuous weld placement.

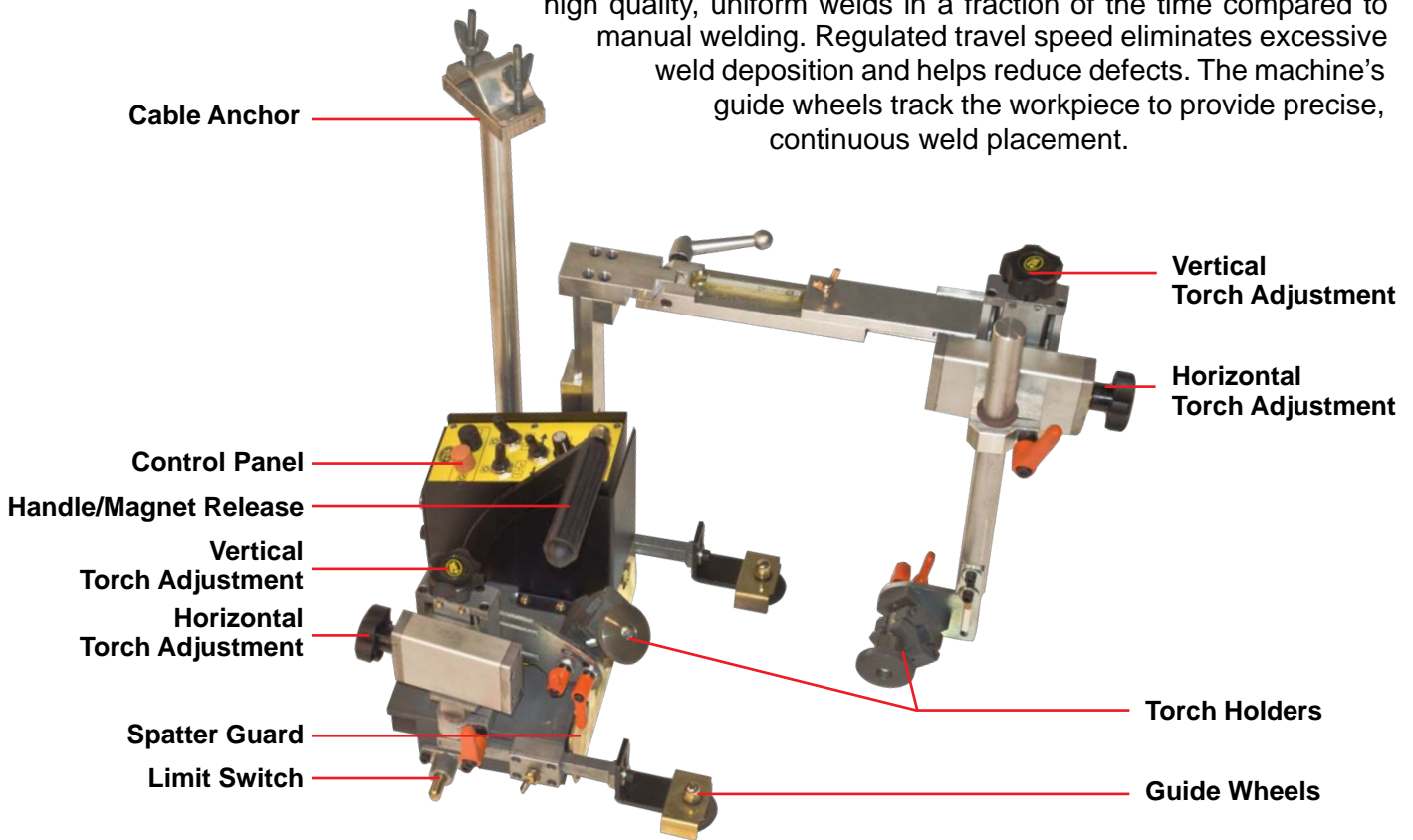

Controls:

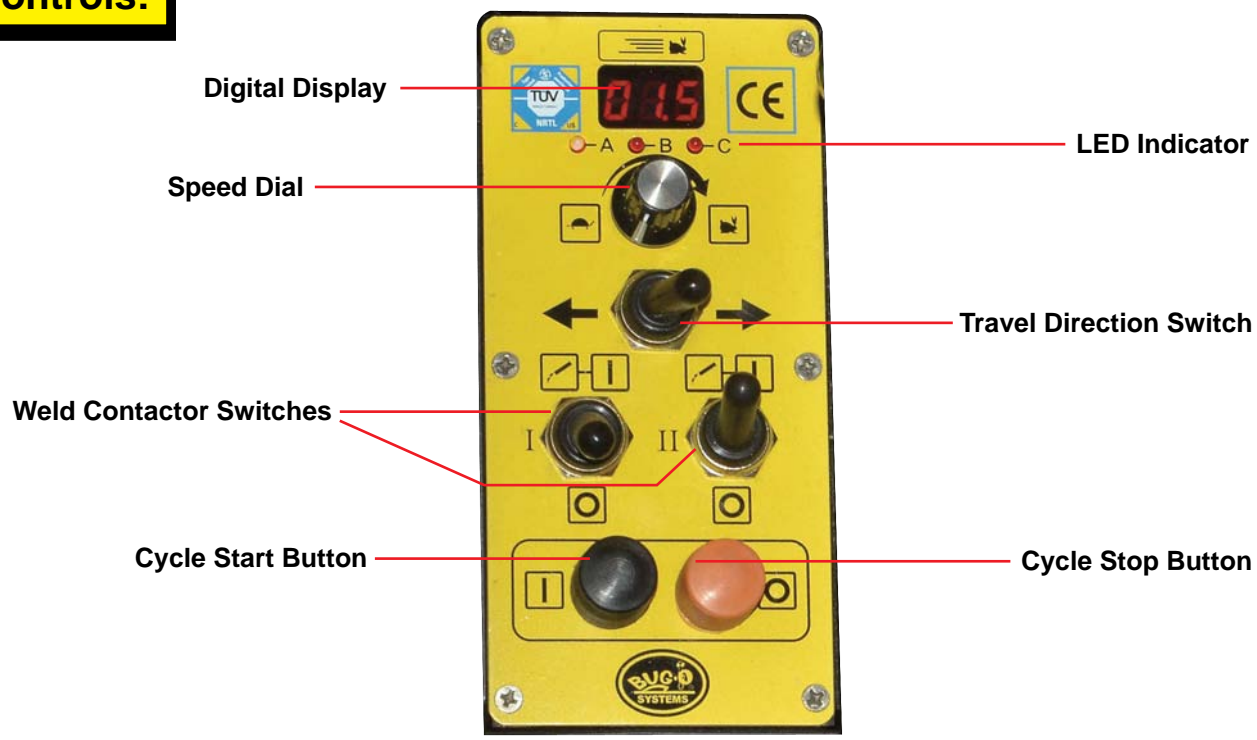



K-BUG 2000 DIGITAL, COMPACT, DUAL TORCH FILLET WELDER

Features:

The **K-Bug 2000** incorporates the following features:

- State of the art digital technology insures accuracy
- High torque, low inertia motor for precise stops and starts
- Drive motor overload protection
- Lightweight carriage with powerful permanent magnets to grip work piece
- Guide wheels track web or flange of work piece
- Closed loop speed control provides adjustable and repeatable control
- Stores travel settings after power is turned off
- Crater fill at the beginning and end of welding
- Two (2) Weld Contactor Enable switches to independently activate each welding torch
- Carriage Travel and arc start in one switch
- Built-in Limit Switches stop tractor travel and welding when activated
- Will climb up a 75° incline
- Digital programming of weld length, skip length and total travel distance



CONTINUOUS WELD

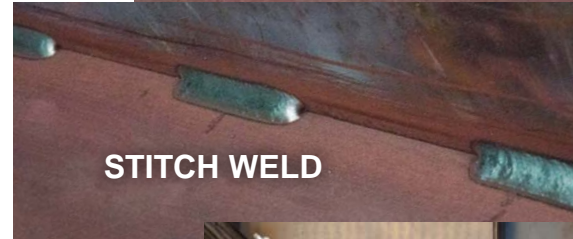

STITCH WELD



Overhead view of K-Bug 2000 in position for down-hand welding.

Accessories:

MSQ-150 ON/OFF Magnetic Stop
For limit switch activation



KBUG-2067 Magwheel guide add-on kit
For welding curved or irregular shapes



SBG-450-L-(A)-(B) 450 Amp Gun/Lincoln 3/4" (19 mm)
For LN7, LN8, LN9, LN25, LN742,
Synergic 7 & LN10 w/ adapter

SBG-450-T-(A)-(B) 450 Amp Gun/Lincoln Std.
For all other Lincoln products

SBG-450-M-(A)-(B) 450 Amp Gun/Miller

SBG-450-E-(A)-(B) 450 Amp Gun/Euro

(A)- Contact Tip Size 0.035" to 1/16" (0.89 to 1.59 mm)

(B)- Cable Length 15 ft (4.57 m) / 25 ft (7.62 m)

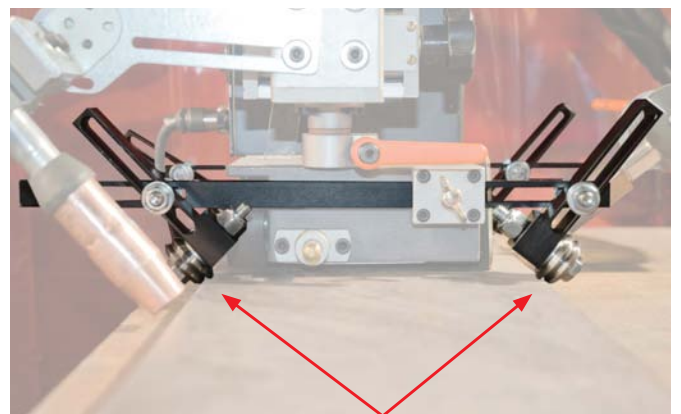

KBUG-2070-__ Four wheel beam guide arm kit

KBUG-2070-6 For 6 - 8" (152 - 203 mm)
flat bar stiffeners

KBUG-2070-12 For 8 - 12" (203 - 304 mm)
flat bar stiffeners



K-BUG 2000 DIGITAL, COMPACT, DUAL TORCH FILLET WELDER

Technical Data:

Part Numbers:	KBUG-2000 (120VAC) KBUG-2002 (240VAC) KBUG-2004 (42VAC)
Power:	120VAC/50-60Hz/1Ph 240VAC/50-60Hz/1Ph 42VAC/50-60Hz/1Ph
Net Weight:	23.2 lbs (10.5 kg)
Shipping Weight:	28.6 lbs (13 kg)
Shipping Dimensions:	20" x 19" x 15" (508 x 483 x 381 mm)
Welding Position:	Flat "down hand" position
Pulling Power:	11 lbs (5 kg)
Torch Holder:	Fits straight torch
Travel Speed:	0.3 - 37 in/min (0.1 - 95 cm/min)
Max Stiffener Height:	11.81" (300 mm)

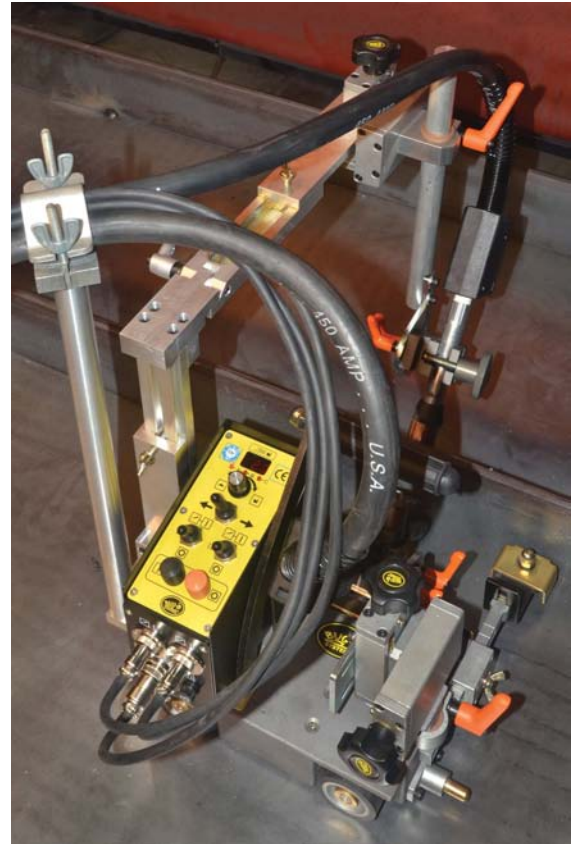

Dimensions:

