

VSK

Special tools for grinding conical valve seats

DN 8-300 mm (1/4-12")

VSK tools facilitate the quick repair of conical sealing faces on all shut-off and control valves with nominal diameter 8-300 mm.

VSK tools prove their strength everywhere where fast valve repair and economy are required:

- **Wide-ranging use:**
in conventional power stations, nuclear power stations, refurbishment companies, refineries, chemical plant, shipyards, sugar mills, paper mills, on ships, by valve manufacturers and many others.
- **Long life due to the use of:**
 - high-quality materials
 - powerful drives
 - wear-resistant tools
 - stable light-weight design
- **Use independent of:**
 - width and hardness of sealing faces to be machined
 - installation position of fitting (horizontal, vertical)
 - type of fitting
- **Due to its low weight**
 - easy handling
 - hand-held operation
 - fast setting up

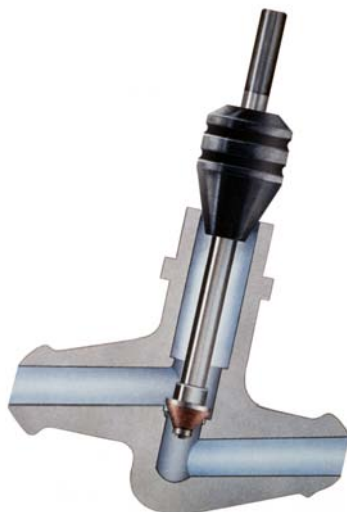

EFCO VSK Tools An impressive Concept

- Simple handling
- Low weight
- One-man operation
- Wear-resistant tools
- Good price/performance ratio
- High profitability and efficiency
- Optimum material removal due to use of high-quality abrasives
- Simple fitting of tools
- Safe centring using centring cone or rim chuck, thus centred machining
- Hard grinding cones to which the abrasive is attached ensure precise angular geometry



VSK Specifications

	VSK-1	VSK-2	VSK-3	VSK-4	VSK-5
DN (mm)	8-50 (¼"-2")	8-65 (¼"-2.5")	8-100 (¼"-4")	8-150 (¼"-6")	80-300 (3"-12")
Drive	electric 230/110 V, 50/60Hz or pneumatic 6-7 bar				
Standard seating angle	30° (2x15°), 40° (2x20°), 60° (2x30°), 75° (2x37,5), 90° (2x45°) (other angles on request)				

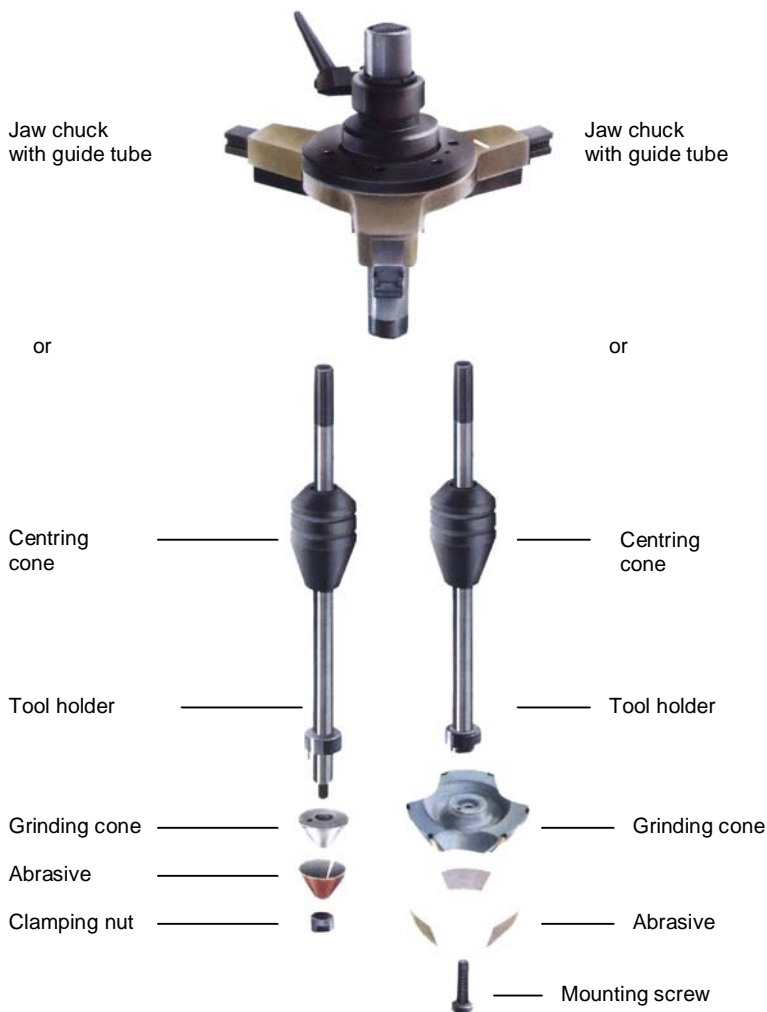

Standard seating angle

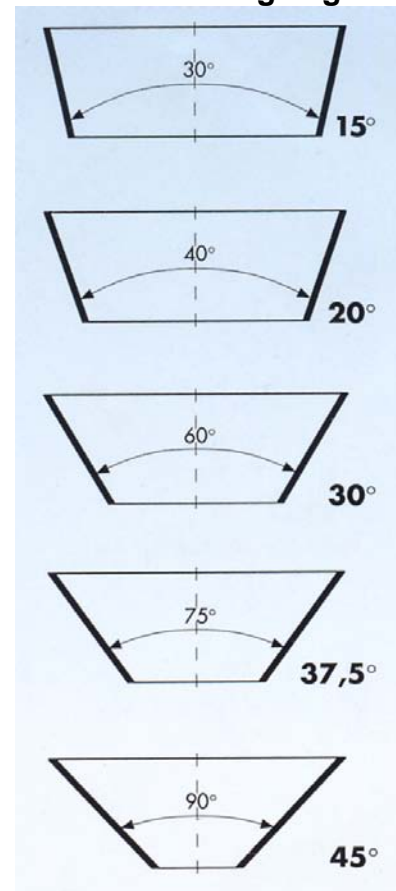

The EFCO VSK tools, as do all EFCO products, provide a complete repair system.

It is possible to combine various angles and sizes into a complete tool set as per your specification.



Subject to technical change.

EFCO Maschinenbau GmbH – Valve repair and testing equipment

Otto-Brenner-Straße 5 – 7 • D - 52353 Düren • Phone: +49-(0)2421-989-0 • Fax: +49-(0)2421-86260

info@efco-dueren.de • sales@efco-dueren.de • www.efco-dueren.com

Agencies in many countries

LS

**Tools for the machining of pipe ends with 140° metallic
lenticular gaskets
(to BASF and DIN 2696)**

DN 8 – 200 mm (3/8"-8")



EFCO-LS with guide bush

Precise special guides provide for completely centred machining of the sealing face.

Guide bushes are used for small nominal diameters.

Even for large diameters, our special jaw chucks enable precise guiding of the grinding tool.

Our EFCO-LS tools are supplied complete with guide bush or rim chuck and an extensive assortment of various abrasive cloths in a plastic carry case.

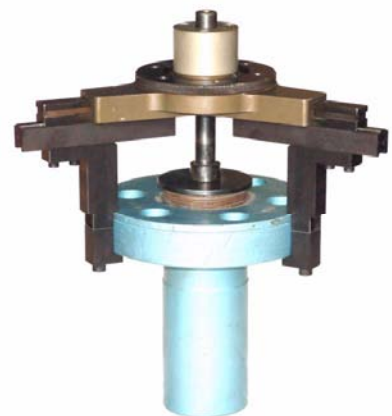

EFCO-LS with jaw chuck

Subject to technical change.

EFCO Maschinenbau GmbH – Valve repair and testing equipment

Otto-Brenner-Straße 5 – 7 • D - 52353 Düren • Phone: +49-(0)2421-989-0 • Fax: +49-(0)2421-86260

info@efco-dueren.de • sales@efco-dueren.de • www.efco-dueren.com

Agencies in many countries