

Glass



Furnaces and Plants for

Tempering
Bending, Slumping, Annealing
Welding
Laminating
Fusing
Melting
Photovoltaics
Quartz Glass Technology
Fiber Optics
Heat Soak
Laboratory

www.nabertherm.com

■ Made
■ in
■ Germany



Made in Germany

Nabertherm with 350 employees worldwide have been developing and producing industrial furnaces for many different applications for over 60 years. As a manufacturer, Nabertherm offers the widest and deepest range of furnaces worldwide. 150,000 satisfied customers in more than 100 countries offer proof of our commitment to excellent design, quality and cost efficiency. Short delivery times are ensured due to our complete inhouse production and our wide variety of standard furnaces.

Setting Standards in Quality and Reliability

Nabertherm does not only offer the widest range of standard furnaces. Professional engineering in combination with inhouse manufacturing provide for individual project planning and construction of tailor-made thermal process plants with material handling and charging systems. Complete thermal processes are realized by customized system solutions.

Innovative Nabertherm control technology provides for precise control as well as full documentation and remote monitoring of your processes. Our engineers apply state-of-the-art technology to improve the temperature uniformity, energy efficiency, reliability and durability of our systems with the goal of enhancing your competitive edge.

Global Sales and Service Network – Close to you

Centralized engineering and manufacturing and decentralized sales and service define our strategy to live up to your needs. Long term sales and distribution partners in all important world markets ensure individual on-site customer service and consultation. There are various reference customers in your neighborhood who have similar furnaces or plants.



Large Customers Test Center

What furnace is the right choice for this specific process? This question cannot always be answered easily. Therefore, we have set up our modern test center which is unique in respect to size and variety. A representative number of furnaces is available for tests for our customers.

Customer Service and Spare Parts

Our professional service engineers are available for you world-wide. Due to our complete inhouse production, we can despatch most spare parts from stock over night or produce with short delivery time.

Experience in Many Fields of Thermal Processing

In addition to furnaces for the glass industry, Nabertherm offers a wide range of standard furnaces and plants for many other thermal processing applications. The modular design of our products provides for customized solutions to your individual needs without expensive modifications.

Table of Contents

	Page
Air Circulation Furnaces	
Air circulation bogie hearth furnaces, electrically heated or gas-fired.....	4
Chamber ovens and dryers, electrically heated or gas-fired heat soak test ovens for toughened safety glass (TSG).....	6
Chamber dryers, electrically heated or gas-fired, ovens for laminated safety glass (LSG).....	8
Ovens, electrically heated also with safety technology according to EN 1539	10
Chamber furnaces with air circulation, electrically heated	12
Clean Room Solutions	13
Furnaces with Radiation Heating	
Bogie hearth furnaces with wire heating up to 1400 °C.....	14
High-temperature bogie hearth furnaces with SiC rod heating up to 1550 °C.....	17
Chamber furnaces with wire heating up to 1400 °C.....	18
Lift-top or lift-bottom furnaces with wire heating up to 1400 °C	22
Top-hat furnaces with SiC rod heating.....	24
Pit-type and top-loading furnaces, electrically heated or gas-fired with or without air circulation	25
High-Temperature Furnaces	
High-temperature chamber furnaces with molybdenum disilicide heating elements with fiber insulation up to 1800 °C	26
High-temperature chamber furnaces with SiC rod heating up to 1550 °C	29
Chamber furnaces with molybdenum disilicide heating elements with refractory insulation up to 1700 °C	30
Gas-fired chamber furnaces up to 1600 °C.....	31
Lift-top and lift-bottom furnaces with molybdenum disilicide heating elements up to 1800 °C	32
Continuous Furnaces, Electrically Heated or Gas-Fired	36
Salt Bath Furnaces for Chemical Hardening of Glass, Electrically Heated or Gas-Fired	38
Annealing and Hardening Furnaces with Wire Heating, Preheating Furnaces for Molds	39
Fusing Furnaces, Tub Furnaces and Top-Hat Furnaces	
Fusing furnaces with wire heating with fixed table	40
Fusing furnaces with wire heating with movable table	42
Tub furnaces with wire heating	44
Top-hat furnaces with wire heating with table	46
Retort Furnaces	
Hot-wall retort furnaces up to 1100 °C	48
Cold-wall retort furnaces up to 2400 °C.....	52
Lift-bottom-retort furnace up to 2400 °C for production	56
Pit-type cold-wall retort furnaces up to 2400 °C or up to 3000 °C	57
Float-Glass Test Kiln with Wire Heating	58
Laboratory Melting Furnace SC 8 with SiC Rod Heating	58
Fast-Firing Decoring Furnaces with Infrared Heating	59
Temperature Uniformity and System Accuracy	60
Process Control and Documentation	61



Air Circulation Bogie Hearth Furnaces, Electrically Heated or Gas-Fired



Bogie hearth furnace with air circulation W 19150/60AS for tempering of semi-finished borosilicate glass products

Bogie hearth furnaces with powerful air circulation are used when an optimal temperature uniformity in the low temperature range is required. They are particularly useful for processes like glass tempering or cooling. With the wide range of additional equipment the furnaces can be individually adapted to the individual process.



Cooling fan for accelerated cooling

- Tmax 600 °C or 850 °C
- Dual shell housing with rear ventilation provides for low shell temperatures for the 850 °C models
- Swing door hinged on the right side
- Heating from chrome steel heating elements in the intake area of the air circulation system for the 600 °C models
- Heating from three sides (both side walls and the trolley) for the 850 °C models
- High-performance air circulation fan with vertical circulation
- Temperature uniformity up to ΔT 10 K according to DIN 17052-1 see page 60
- Bottom heating protected by SiC tiles on the bogie providing level stacking surface for the 850 °C models
- Furnace chamber fitted with inner sheets made of stainless steel 1.4301 for 600 °C models and of 1.4828 for 850 °C models
- Insulation structured with high-quality mineral wool for 600 °C models
- Insulation made of high-quality, non-classified fiber material for 850 °C models
- Bogies with flanged wheels running on rails for easy and precise movement of heavy loads
- Electric chain-driven bogie in combination with rail operation for smooth movement of heavy loads from model W 4800
- Over-temperature limiter with manual reset for thermal protection class 2 in accordance with EN 60519-2 as temperature limiter to protect the furnace and load

Additional equipment

- Direct gas heating or upon request with indirect gas heating with radiation tube
- Custom-built sizes
- Electric chain-driven bogie in combination with rail operation for smooth movement of heavy loads up to Model W 4000
- Optimization of the temperature uniformity up ΔT 6 K according to DIN 17052-1 see page 60
- Bogie running on steel wheels with gear rack drive, no rails in front of the furnace necessary
- Different possibilities for an extension to a bogie hearth furnace system:
 - Additional bogies
 - Bogie transfer system with parking rails to exchange bogies running on rails or to connect multiples furnaces
 - Motor-driven bogies and cross-traversal system
 - Fully automatic control of the bogie exchange
- Electro-hydraulic lift door
- Motor-driven exhaust air flaps, adjustable via the program
- Uncontrolled or controlled cooling system with frequency-controlled cooling fan and motor-driven exhaust air flap
- Multi-zone control adapted to the particular furnace model provides for optimum temperature uniformity in the 850 °C models
- Commissioning of the furnace with test firing and temperature uniformity measurement (also with load) for the purpose of process optimization
- Designed for Tmax 950 °C, fan blade driven indirectly via a belt to protect the air recirculation motor against over-heating
- Process documentation and control with Controltherm MV software package and the Nabertherm NCC control center for monitoring, documentation and control see page 62



W 10430/85AS in custom sizes



W 3300/85S with chain drive

Model	Tmax °C	Inner dimensions in mm			Volume in l	Outer dimensions in mm			Connected load/kW	Electrical connection*
		w	d	h		W	D	H		
W 1000/.. A	600 or 850	800	1600	800	1000	1800	2390	2305	50.0	3-phase
W 1600/.. A		1000	1600	1000	1600	2000	2390	2535	50.0	3-phase
W 2200/.. A		1000	2250	1000	2200	2000	3040	2535	95.0	3-phase
W 3300/.. A		1200	2250	1200	3300	2200	3040	2745	95.0	3-phase
W 4000/.. A		1500	2250	1200	4000	2500	3040	2780	120.0	3-phase
W 4800/.. A		1200	3300	1200	4800	2200	4090	2780	120.0	3-phase
W 6000/.. A		1500	3300	1200	6000	2500	4090	2900	156.0	3-phase
W 6600/.. A		1200	4600	1200	6600	2200	5390	2770	152.0	3-phase
W 7500/.. A		1400	3850	1400	7500	2400	4640	2980	154.0	3-phase
W 8300/.. A		1500	4600	1200	8300	2500	5390	2780	203.0	3-phase

*Please see page 61 for more information about supply voltage

Chamber Ovens and Dryers, Electrically Heated or Gas-Fired Heat Soak Test Ovens for Toughened Safety Glass (TSG)



N 4010/45 HA



N 12000/26 HA with individual custom measurements

N 560/26.. - N 10000/45...

These chamber ovens are available for maximum working temperatures of 260 °C or 450 °C. They are suitable for numerous processes such as pre-heating of moulds, ageing or drying.

The version suitable for temperatures up to 450 °C is recommended for Heat Soak testing of Toughened Safety Glass (TSG). During a Heat Soak Test in accordance with EN 14179-1 the panes are exposed to a temperature of 290 °C for at least four hours in order to transform nickel sulfide inclusions and hence to prevent the pane from breaking spontaneously later. The documentation of the heat treatment process is strongly recommended. Program entry, visualization and the documentation of the process are achieved by means of the PLC-control in combination with the powerful Nabertherm Control Center (NCC), which registers and archives the temperatures at different measuring points on the pane.

- Tmax 260 °C or 450 °C
- Heated electrically or with gas
- Electrical heating by means of heater coils
- Direct gas heating or optionally indirect gas heating with temperature transfer via steel tube or heat exchanger
- Available with horizontal (type/HA) or vertical air circulation (type/A) for optimal uniformity in your charge
- Ground level charging without floor insulation for 260 °C models
- Temperature uniformity up to ΔT 6 K according to DIN 17052-1 see page 60
- Optimal air circulation for your charge by means of adjustable air outlets
- Furnace chamber lined with alloy 314 (AISI)/(DIN material no. 1.4841)
- Low shell temperature by means of high quality mineral wool insulation
- Manually adjustable air inlet and exhaust air vent
- High air exchange for fast drying processes
- Furnace sizes suitable for common charging systems, such as pallets, baskets, etc.
- Zweiflügelige Tür ab einer Innenraumbreite von 1500 mm, kleinere Größen sind mit einer einflügeligen Tür ausgestattet
- Over-temperature limiter with manual reset for thermal protection class in accordance with EN 60519-2 as temperature limiter controller to protect the oven and load
- Controls description see page 61



N 2880/60HAS for glass cooling with frame for opening of individual chamber segments



Adjustable air outlets for optimization of the temperature uniformity



2 x N 10000/45HA

Additional equipment

- Data recording via Nabertherm Control Center (NCC) in accordance with the requirements of EN 141791 for Heat Soak Tests of Tempered Safety Glass (TSG)
- Racks for loading of standing glass panes
- Optional floor insulation for improved temperature uniformity on 260 °C models
- Entry ramp or track cutouts for floor-level charging cart of models with insulated bottom
- Electro-hydraulic lift door
- Fan system for faster cooling with manual or automatic control
- Motor-driven control of exhaust air flaps for better ventilation of the furnace chamber
- Window and furnace chamber illumination
- Safety technology according to EN 1539 for charges containing solvents
- Catalytic or thermal exhaust gas cleaning systems
- Custom sizes up to 40,000 liters and charge weights up to 30 tons



Loading rack for glass panes

Model	Tmax °C	Inner dimensions in mm			Volume in l	Circulation rate m³/h	Connected load/kW		Electrical connections*
		w	d	h			260 °C	450 °C	
N 9900/.. A	260 or 450	1500	3000	2200	9900	21500	85.0	85.0 ¹ /100.0	3-phase
N 17600/.. A	260 or 450	2000	4000	2200	17600	33000	130.0	130.0 ¹ /145.0	3-phase
N 41600/.. A	260 or 450	2000	6500	3200	41600	64000	200.0	200.0 ¹ /230.0	3-phase
N 560/..	260 or 450	750	1000	750	560	900	13.0	13.0 ¹ / 19.0	3-phase
N 1000/..	260 or 450	1000	1000	1000	1000	3600	18.0	18.0 ¹ / 40.0	3-phase
N 1500/..	260 or 450	1500	1000	1000	1500	3600	22.0	22.0 ¹ / 40.0	3-phase
N 1500/..1	260 or 450	1000	1500	1000	1500	3600	22.0	22.0 ¹ / 40.0	3-phase
N 2000/..	260 or 450	1500	1100	1200	2000	6400	22.0	22.0 ¹ / 46.0	3-phase
N 2000/..1	260 or 450	1100	1500	1200	2000	6400	22.0	22.0 ¹ / 46.0	3-phase
N 2010/..	260 or 450	1000	1000	2000	2000	7200	30.0	30.0 ¹ / 54.0	3-phase
N 2880/..	260 or 450	1200	1200	2000	2880	9000	54.0	54.0 ¹ / 66.0	3-phase
N 4000/..	260 or 450	1500	2200	1200	4000	9000	47.0	47.0 ¹ / 65.0	3-phase
N 4000/..1	260 or 450	2200	1500	1200	4000	9000	47.0	47.0 ¹ / 65.0	3-phase
N 4010/..	260 or 450	1000	2000	2000	4000	9000	54.0	54.0 ¹ / 66.0	3-phase
N 4500/..	260 or 450	1500	1500	2000	4500	12800	54.0	54.0 ¹ / 66.0	3-phase
N 5600/..	260 or 450	1500	2500	1500	5600	9000	69.0	69.0 ¹ / 93.0	3-phase
N 6750/..	260 or 450	1500	3000	1500	6750	19200	98.0	98.0 ¹ /116.0	3-phase
N 7200/..	260 or 450	2000	1500	2400	7200	18000	93.0	93.0 ¹ /117.0	3-phase
N 10000/..	260 or 450	2000	2500	2000	10000	25600	106.0	106.0 ¹ /130.0	3-phase

¹Reduced connected power for plastics applications

*Please see page 61 for more information about supply voltage



Temperature recording in accordance with EN 14179-1

Chamber Dryers, Electrically Heated or Gas-Fired Ovens for Laminated Safety Glass (LSG)



Standard models

The chamber dryers of the KTR range can be used for complex drying processes and heat treatment of charges of normal weight and packing density to an application temperature of 260 °C. The high-performance air circulation enables optimum temperature uniformity throughout the work space. A wide range of accessories allow the furnace to be modified to meet specific process requirements.

The chamber dryers can also be used for production of laminated safety glass (LSG). During this process two panes are bonded using a laminating foil and entered into the oven inside a vacuum bag. From outside the furnace a vacuum is generated via hose connection in order to avoid air inclusions between the panes during the heat treatment.

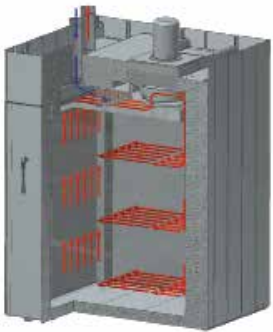

Air circulation in the chamber dryer

- Tmax 260 °C
- Electrically heated (via a heating register with integrated chrome steel heating elements) or gas-fired (direct gas heating including injection of the hot air into the intake duct)
- Temperature uniformity up to ΔT 6 K according to DIN 17052-1 (for design without track cutouts) see page 60



Charging cart with pull-out trays



KTR 8000 with clean room specs



KTR 6125



KTR 1500 with charging cart

- High-quality mineral wool insulation provides for outer temperatures of < 20 °C above room temperature
- High air exchange for fast drying processes
- Double-wing door for furnaces KTR 3100 and larger
- Over-temperature limiter with manual reset for thermal protection class 2 in accordance with EN 60519-2 as temperature limiter to protect the dryer and load
- Incl. floor insulation
- Controls description see page 61

Additional equipment

- Entry ramp for pallet trucks or track cutouts for charging cart
- Connection ports for vacuum bags inside the oven for laminated safety glass (LSG). The vacuum pump is connected on the outside of the furnace.
- Optimal air circulation for individual charges by means of adjustable air outlets
- Fan system for faster cooling with manual or motor-driven control
- Programmed opening and closing of exhaust air flaps
- Observation window and furnace chamber lighting
- Safety technology according to EN 1539 for charges containing solvents
- Charging cart with or without rack system
- Custom-built sizes
- Design for clean room heat treatment processes see page 13
- Process control and documentation with Controltherm MV software package see page 63



KTR 3100/S for curing of composites in vacuum bags incl. pump and necessary connections in the oven chamber

Model	Tmax °C	Inner dimensions in mm			Volume in l	Outer dimensions in mm			Connected load kW	Electrical connection*
		w	d	h		W	D	H		
KTR 1500	260	1000	1000	1500	1500	1930	1430	2315	21.0	3-phase
KTR 3100	260	1250	1250	2000	3100	2160	1680	2880	30.0	3-phase
KTR 4500	260	1500	1500	2000	4500	2410	1930	2880	48.0	3-phase
KTR 6125	260	1750	1750	2000	6125	2660	2180	3000	50.0	3-phase
KTR 8000	260	2000	2000	2000	8000	2910	2430	3000	59.0	3-phase

*Please see page 61 for more information about supply voltage



N 12012/26 HAS1 N with drawer shelves

Ovens, Electrically Heated also with Safety Technology According to EN 1539



TR 60 with adjustable fan speed



TR 240



Electrical rotating device as additional equipment



Extricable metal grids to load the oven in different layers

TR 60 - TR 1050

With their maximum working temperature of up to 300 °C and forced air circulation, the ovens achieve a perfect temperature uniformity which is much better than in ovens of most competitors. They can be used for various applications such as e.g. drying, sterilizing or warm storing. Ample warehousing of standard models provides for short delivery times.

- Tmax 300 °C
- Working range: + 5 °C above room temperature up to 300 °C
- Models TR 60 - TR 240 designed as tabletop models
- Models TR 450 and TR 1050 designed as floor standing models
- Horizontal, forced air circulation results in temperature uniformity better than ΔT 8 K see page 60
- Stainless steel chamber, alloy 304 (AISI)/(DIN material no. 1.4301), rust-resistant and easy to clean
- Large handle to open and close the door
- Charging in multiple layers possible using removeable grids (number of removeable grids included, see table to the right)
- Large, wide-opening swing door, hinged on the right with quick release for models TR 60 - TR 450
- Double swing door with quick release for TR 1050
- TR 1050 equipped transport rollers
- Infinitely adjustable exhaust at the rear wall with operation from the front
- PID microprocessor control with self-diagnosis system
- Solid state relays provide for lownoise operation
- Controls description see page 61

Additional equipment

- Over-temperature limiter with manual reset for thermal protection class 2 in accordance with EN 60519-2 as temperature limiter to protect the furnace and load
- Infinitely adjustable fan speed of the air circulation fan
- Window for charge observing



TR 450 with observation window



TR 1050 with double door

- Further removeable grids with rails
- Side inlet
- Stainless steel collecting pan to protect the furnace chamber
- Safety Technology according to EN 1539 for charges (TRS) containing liquid solvents up to model TRS 240, achievable temperature uniformity ΔT 16 K see page 60
- Transport costors for model TR 450
- Various modifications available for individual needs
- Upgrading available to meet the quality requirements of AMS 2750 E or FDA
- Process control and documentation with Controltherm MV software package see page 63



TR 60 with observation window

Model	Tmax °C	Inner dimensions in mm			Volume in l	Outer dimensions in mm			Connected load kW ²	Electrical connection*	Weight in kg	Grids in- cluded	Grids max.	Max. total load ¹
		w	d	h		W	D	H						
TR 60	300	450	380	350	60	700	650	690	3.0	1-phase	90	1	4	120
TRS 60	260	450	360	350	57	700	680	690	6.3	3-phase	92	1	4	120
TR 120	300	650	380	500	120	900	650	840	3.1	1-phase	120	2	7	150
TRS 120	260	650	360	500	117	900	680	840	6.3	3-phase	122	2	7	150
TR 240	300	750	550	600	240	1000	820	940	3.1	1-phase	165	2	8	150
TRS 240	260	750	530	600	235	1000	850	940	6.3	3-phase	167	2	8	150
TR 450	300	750	550	1100	450	1000	820	1440	6.3	3-phase	235	3	15	180
TR 1050	300	1200	630	1400	1050	1470	955	1920	9.3	3-phase	450	4	14	250

¹Max load per layer 30 kg

*Please see page 61 for more information about supply voltage

²If EN 1539 is ordered power rating will increase

Chamber Furnaces with Air Circulation, Electrically Heated



N 120/65 HA



N 60/85HA with torch as additional equipment



N 15/65HA as table-top model

N 15/65HA, N 30/45HA - N 500/85HA

These chamber furnaces with air circulation are characterized by their extremely high temperature uniformity. Hence, they are especially suitable for processes such as cooling, crystalizing, pre-heating, curing, but also for numerous processes in tool making. Due to the modular concept, the furnaces can be adjusted to the process requirements by adding suitable equipment.

- Tmax 450 °C, 650 °C, or 850 °C
- Horizontal air circulation
- Swing door hinged on the right
- Temperature uniformity up to ΔT 8 K according to DIN 17052-1 see page 60
- Heating from bottom, sides and top
- Optimum air flow and temperature uniformity through high circulation rates
- One shelf and rails for two additional shelves included (N 15/65 HA without removable tray)
- Air baffle box of stainless steel inside the furnace chamber for optimum air circulation
- Base frame included in the delivery, N 15/65 HA designed as table-top model
- Switchgear with solid-state relays
- Controls description see page 61

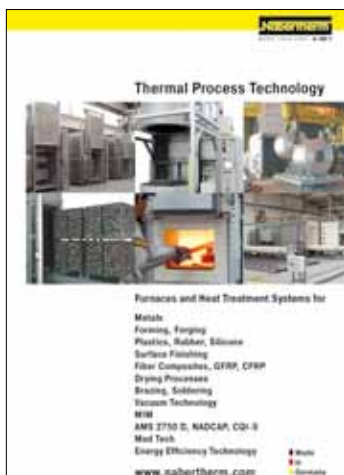

For additional information about chamber furnaces with air circulation please ask for our separate catalog!

Model	Tmax °C	Inner dimensions in mm			Volume in l	Outer dimensions in mm			Connected load kW	Electrical connection*	Weight in kg
		w	d	h		W	D	H			
N 30/45 HA	450	290	420	260	30	607 + 255	1175	1315	3.6	1-phase	195
N 60/45 HA	450	350	500	350	60	667 + 255	1250	1400	6.6	3-phase	240
N 120/45 HA	450	450	600	450	120	767 + 255	1350	1500	9.6	3-phase	310
N 250/45 HA	450	600	750	600	250	1002 + 255	1636	1860	19.0	3-phase	610
N 500/45 HA	450	750	1000	750	500	1152 + 255	1886	2010	28.0	3-phase	1030
N 15/65 HA ¹	650	295	340	170	15	470	845	460	2.7	1-phase	55
N 30/65 HA	650	290	420	260	30	607 + 255	1175	1315	6.0	3-phase ²	195
N 60/65 HA	650	350	500	350	60	667 + 255	1250	1400	9.6	3-phase	240
N 120/65 HA	650	450	600	450	120	767 + 255	1350	1500	13.6	3-phase	310
N 250/65 HA	650	600	750	600	250	1002 + 255	1636	1860	21.0	3-phase	610
N 500/65 HA	650	750	1000	750	500	1152 + 255	1886	2010	31.0	3-phase	1030
N 30/85 HA	850	290	420	260	30	607 + 255	1175	1315	6.0	3-phase ²	195
N 60/85 HA	850	350	500	350	60	667 + 255	1250	1400	9.6	3-phase	240
N 120/85 HA	850	450	600	450	120	767 + 255	1350	1500	13.6	3-phase	310
N 250/85 HA	850	600	750	600	250	1002 + 255	1636	1860	21.0	3-phase	610
N 500/85 HA	850	750	1000	750	500	1152 + 255	1886	2010	31.0	3-phase	1030

¹Table-top model

²Heating only between two phases

*Please see page 61 for more information about supply voltage

Clean Room Solutions

Clean room applications impose particularly high requirements to the design of the chosen furnace. If the complete furnace is operated in a clean room an essential contamination of the clean room atmosphere must be avoided. Especially, the particle contamination must be reduced to a minimum.

The specific application determines the choice of the required oven or furnace type. In many cases air circulation furnaces are required to achieve the necessary temperature uniformity at lower temperatures. For higher temperatures, Nabertherm has also delivered many furnaces with radiant heating.

Furnace Installation in the Clean Room

If the complete furnace is supposed to be positioned in the clean room, then it is important that both the furnace chamber and the furnace housing as well as the controls provide for good protection against contamination. Surfaces must be easy to clean. The furnace chamber is tightly sealed to the insulation behind it. If necessary, additional equipment such as filters for the fresh air supply or the air circulation in the furnace can be used to improve the cleanliness class. It is recommended to install the switchgear and the furnace controls outside the clean room.

Furnace Installation in the Grey Room, Furnace Charging from the Clean Room

An easy installation alternative to improve cleanliness is placing the furnace in the grey room with charging from the clean room. This significantly reduces the amount of costly space needed in the clean room to a minimum. The front and the furnace interior in the clean room are designed for easy cleaning. With this configuration even the highest clean room classes can be achieved.

Furnace with Double Door System as lock between Grey Room and Clean Room

Logistics between clean room and grey room can often be easily sorted out. Lock furnaces with one door in the grey room and the other door in the clean room are the perfect choice for these applications. The inner chamber as well as the furnace front in the clean room will be especially designed for lowest particle contamination.

Please contact us if you are looking for a heat treatment solution under clean room conditions. We would be pleased to quote for the oven or furnace model that meets best your requirements.



KTR 8000 designed as a production furnace in the clean room with filters for air recirculation



Air circulation chamber furnace NAC 120/65 with clean room specs



Air circulation furnace N 250/65 HAC for clean room Class 100 with charging door to the clean room



Hot-wall retort furnace NRA 1700/06 with charging frame for installation in grey room with charging door in clean room

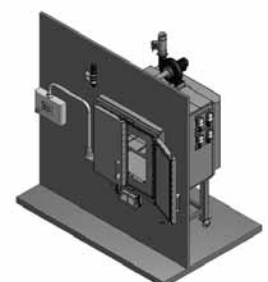

Clean/Grey room solution with charging and operating in clean room

Bogie Hearth Furnaces with Wire Heating up to 1400 °C



W 1500/H



Bogie hearth furnace W 2060/S, customized without bogie heating for preheating fusion molds



Bogie hearth furnace for tempering quartz rods



Bogie hearth furnace W 3300 for crucible coating

W 1000 - W 10000/14, W 1000/DB - W 10000/14DB

When cooling, decorating, glazing or sintering special glass during production, bogie hearth furnaces offer numerous advantages. Due to their very good temperature uniformity, these models are perfectly suited for burning in a separation layer of silicon nitride in crucibles for the solar industry. The bogie can be charged outside the furnace. Several shuttles can be used, so that one shuttle can be charged while the other shuttle is in the furnace.

- Tmax 1280 °C, 1340 °C or 1400 °C
- Dual shell housing with rear ventilation, provides for low shell temperatures
- Swing door hinged on the right side
- Heating from five sides (four sides and bogie) provides for an optimum temperature uniformity
- Bogie heating receives power via blade contacts when driven in
- Heating elements mounted on support tubes provide for free radiation and long service life
- Bottom heating protected by SiC tiles on the bogie providing level stacking surface
- Multi-layer insulation consisting of lightweight refractory bricks backed by microporous silica insulation
- Self-supporting and long-life ceiling construction with bricks laid in arched construction, for models up to 1340 °C or as fiber insulation
- Roof made of high-quality fiber material for models with Tmax 1400 °C
- Bgies freely movable with rubber tires
- Adjustable air inlet damper
- Manual exhaust air flap on the furnace roof
- Over-temperature limiter with manual reset for thermal protection class 2 in accordance with EN 60519-2 as temperature limiter to protect the furnace and load



W 8250/S in customized dimensions for tempering quartz glass

Additional equipment

- Customized dimensions
- Fiber insulation for short heating time requirements
- Bogies with flanged wheels running on rails for easy and precise movement of high loads or complex kiln furniture
- Electric chain-driven bogie in combination with rail operation for smooth movement of heavy loads
- Bogie running on steel wheels with gear rack drive, no rails in front of the furnace necessary
- Different possibilities for an extension to a bogie hearth furnace system:
 - Additional bogies
 - Bogie transfer system with parking rails to exchange bogies running on rails or to connect multiples furnaces
 - Motor-driven bogies and cross-traversal system
 - Fully automatic control of the bogie exchange
- Electro-hydraulic lift door
- Customized kiln furniture
- Motor-driven exhaust air flap, switchable via the program
- Uncontrolled or controlled cooling system with frequency-controlled cooling fan and motor-driven exhaust air flap
- Multi-zone control adapted to the particular furnace provides model for optimal the temperature uniformity
- Commissioning of the furnace with test firing and temperature uniformity measurement (also with load) for the purpose of process optimization
- Thermal or catalytic exhaust cleaning systems
- Process documentation and control with Controltherm MV software package, NTLog and NTGraph for the basic furnace or Nabertherm Control Center (NCC) for monitoring, documentation and control see page 62



Bogie hearth furnace with gas box for non-flammable protective or reaction gases



Bogie hearth furnace with gas box for non-flammable protective or reaction gases

Bogie Hearth Furnaces with Wire Heated up to 1400 °C

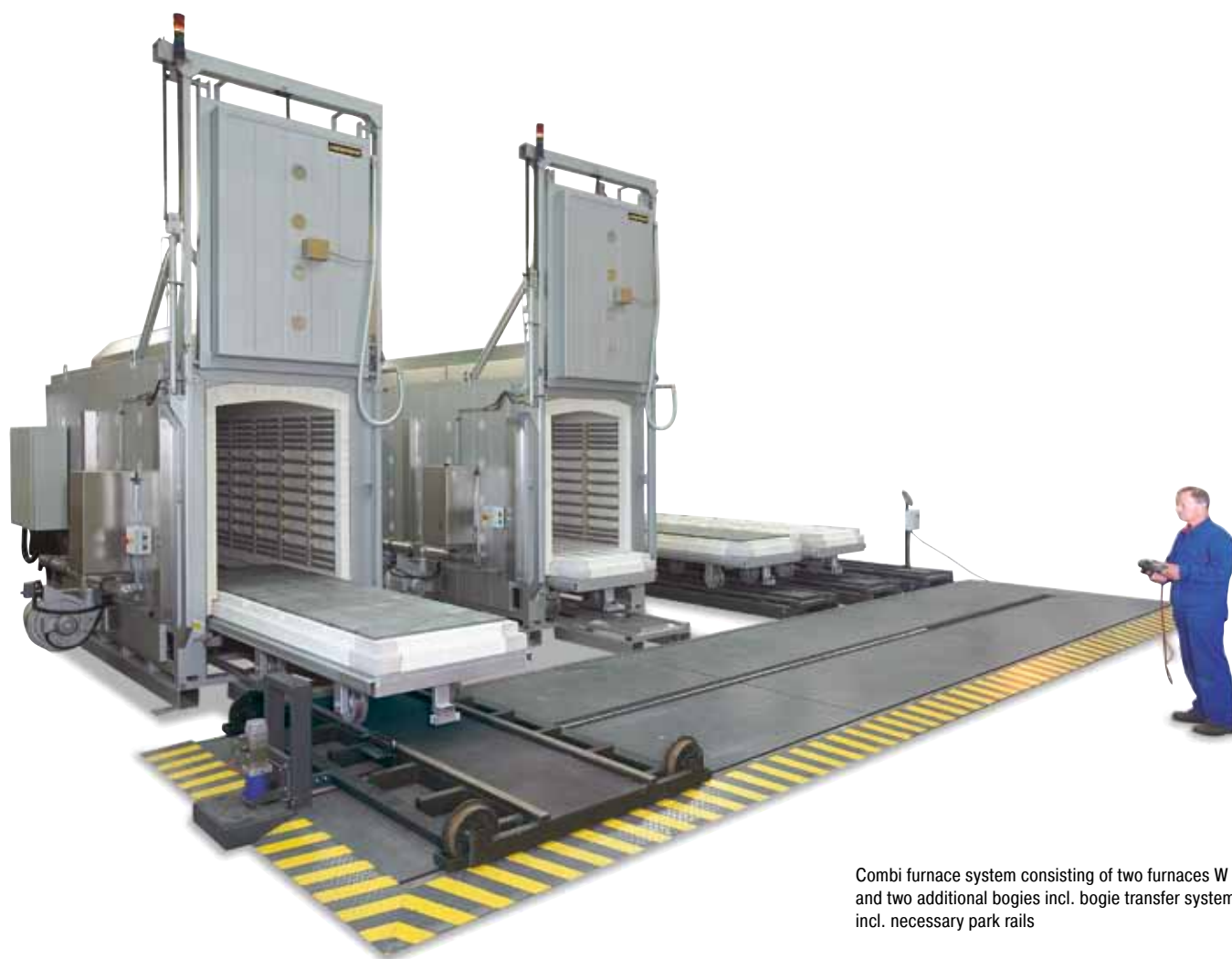

Combi furnace system consisting of two furnaces W 5000/H and two additional bogies incl. bogie transfer system and incl. necessary park rails

Model	Tmax °C	Inner dimensions in mm			Volume in l	Outer dimensions in mm			Connected load kW	Electrical connection*	Weight in kg
		w	d	h		W	D	H			
W 1000/G	900	800	1600	800	1000	1470	2400	1820	40	3-phase	3000
W 1500/G	900	900	1900	900	1500	1570	2700	2010	57	3-phase	3500
W 2200/G	900	1000	2200	1000	2200	1670	3000	2120	75	3-phase	4000
W 3300/G	900	1000	2800	1200	3300	1670	3600	2320	110	3-phase	5300
W 5000/G	900	1000	3600	1400	5000	1670	4400	2520	140	3-phase	7500
W 7500/G	900	1000	5400	1400	7500	1670	6200	2520	185	3-phase	9100
W 10000/G	900	1000	7100	1400	10000	1670	7900	2520	235	3-phase	11000
W 1000	1280	800	1600	800	1000	1470	2400	1820	57	3-phase	3000
W 1500	1280	900	1900	900	1500	1570	2700	2010	75	3-phase	3500
W 2200	1280	1000	2200	1000	2200	1670	3000	2120	110	3-phase	4000
W 3300	1280	1000	2800	1200	3300	1670	3600	2320	140	3-phase	5300
W 5000	1280	1000	3600	1400	5000	1670	4400	2520	185	3-phase	7500
W 7500	1280	1000	5400	1400	7500	1670	6200	2520	235	3-phase	9100
W 10000	1280	1000	7100	1400	10000	1670	7900	2520	300	3-phase	11000
W 1000/H	1340	800	1600	800	1000	1470	2400	1820	75	3-phase	3500
W 1500/H	1340	900	1900	900	1500	1570	2700	2010	110	3-phase	4000
W 2200/H	1340	1000	2200	1000	2200	1670	3000	2120	140	3-phase	5000
W 3300/H	1340	1000	2800	1200	3300	1670	3600	2320	185	3-phase	6000
W 5000/H	1340	1000	3600	1400	5000	1670	4400	2520	235	3-phase	8000
W 7500/H	1340	1000	5400	1400	7500	1670	6200	2520	370	3-phase	11300
W 10000/H	1340	1000	7100	1400	10000	1670	7900	2520	440	3-phase	13800
W 1000/14	1400	800	1600	800	1000	1470	2400	1820	75	3-phase	3300
W 1500/14	1400	900	1900	900	1500	1570	2700	2010	110	3-phase	3800
W 2200/14	1400	1000	2200	1000	2200	1670	3000	2120	140	3-phase	4800
W 3300/14	1400	1000	2800	1200	3300	1670	3600	2320	185	3-phase	5700
W 5000/14	1400	1000	3600	1400	5000	1670	4400	2520	235	3-phase	7700
W 7500/14	1400	1000	5400	1400	7500	1670	6200	2520	370	3-phase	10900
W 10000/14	1400	1000	7100	1400	10000	1670	7900	2520	440	3-phase	13300

*Please see page 61 for more information about supply voltage

High-Temperature Bogie Hearth Furnaces with SiC Rod Heating up to 1550 °C



WHTC 3300/15

WHTC 4000/15 with bogie on rails and fan cooling

Bogie hearth furnaces equipped with SiC rod heating can be used for processes up to 1550 °C. The WHTC product line with especially robust design can hold heavy charges including kiln furniture. The furnace chamber is equipped with a high-quality insulation made of high-temperature fiber blocks. The bogie insulation is structured in multi-layer lightweight refractory bricks on the heating chamber side.

The furnace is heated along both sides by vertically installed SiC heating rods. This heating technology permits processes requiring working temperatures above 1350 °C which cannot be achieved with wire heating elements. The SiC rods are controlled by thyristor controller which counteract the aging of the heating elements by means of automatic power compensation.

- Tmax 1550 °C
- Dual shell housing with rear ventilation, provides for low shell temperatures
- Swing door hinged on the right side
- Heating from both sides via vertically mounted SiC rods
- Thyristor controllers with automatic output compensation counteract the aging of SiC rods
- Multi-layer insulation with high-quality fiber modules on the heating chamber side
- Bogie for heavy loads lined with lightweight refractory bricks
- Bogie hand driven on rubber tires
- Motor-driven exhaust air flap on the furnace roof
- Over-temperature limiter with manual reset for thermal protection class 2, as defined in EN 60519-2, to protect the furnace and charge

Additional equipment

The WHTC bogie hearth furnaces can be equipped with extensive additional equipment to be optimally adapted to individual processes. For additional equipment see page 15.



SiC rod elements on both sides of the furnace



Design with two doors and two bogies, on rails, allows for rapid bogie changes

Chamber Furnaces with Wire Heating up to 1400 °C



Customized furnace N 2900

N 100 - N 2200/14

These high-quality chamber furnaces for firing, sintering and tempering have qualified themselves with the reliability for many years in daily use. Thanks to their five-side heating, the furnaces provide for a very good temperature uniformity. A wide range of additional equipment perfectly adapt these models to the process requirements.

- Tmax 1300 °C, 1340 °C or 1400 °C
- Five-side heating provide for good temperature uniformity
- Heating elements on support tubes provide for free heat radiation and long service life
- Vapour vent in the middle of the roof (excellent ventilation)
- Smoothly adjustable and easy-to-operate air inlet flap or sliding damper
- Self-supporting and long-life ceiling construction, with bricks laid in arched construction
- Special door lock for easy handling
- Multi-layer insulation consisting of lightweight refractory bricks and backed by special fiber insulation
- Models up to N 300/.. with removable stand
- Bottom heating elements protected by SiC tiles for level stacking surface
- Controls description see page 61

Additional equipment

- Motor-driven exhaust air flap
- Fan system for faster cooling with manual or automatic control
- Protective gas connection for purging the furnace with non-flammable protective or reaction gases
- Manual or automatic gas supply systems
- Fiber-insulation for shorter cycle times, especially cooling periods

- Multi-zone control for optimal temperature uniformity in the useful chamber
- Over-temperature limiter with manual reset for thermal protection class 2 in accordance with EN 60519-2 as temperature limiter to protect the furnace and load



N 4260/S for production for fiber-optic cables



Chamber kiln N 200 for tempering



Model	Tmax °C	Inner dimensions in mm			Volume in l	Outer dimensions in mm			Connected load kW	Electrical connection*	Weight in kg
		w	d	h		W	D	H			
N 100/G	900	400	530	460	100	710	1150	1430	7	3-phase	270
N 150/G	900	450	530	590	150	760	1150	1560	9	3-phase	305
N 200/G	900	500	530	720	200	810	1150	1690	11	3-phase	345
N 300/G	900	550	700	780	300	860	1340	1750	15	3-phase	430
N 440/G	900	600	750	1000	450	1000	1450	1820	20	3-phase	700
N 660/G	900	600	1100	1000	660	1000	1800	1820	26	3-phase	850
N 1000/G	900	800	1000	1250	1000	1450	1850	2000	40	3-phase	1800
N 1500/G	900	900	1200	1400	1500	1550	2050	2160	57	3-phase	2500
N 2200/G	900	1000	1400	1600	2200	1650	2250	2360	75	3-phase	3100
N 100	1300	400	530	460	100	710	1150	1430	9	3-phase	270
N 150	1300	450	530	590	150	760	1150	1560	11	3-phase	305
N 200	1300	500	530	720	200	810	1150	1690	15	3-phase	345
N 300	1300	550	700	780	300	860	1340	1750	20	3-phase	430
N 440	1300	600	750	1000	450	1000	1450	1820	30	3-phase	700
N 660	1300	600	1100	1000	660	1000	1800	1820	40	3-phase	850
N 1000	1300	800	1000	1250	1000	1450	1850	2000	57	3-phase	1800
N 1500	1300	900	1200	1400	1500	1550	2050	2160	75	3-phase	2500
N 2200	1300	1000	1400	1600	2200	1650	2250	2360	110	3-phase	3100
N 100/H	1340	400	530	460	100	710	1150	1430	11	3-phase	315
N 150/H	1340	450	530	590	150	760	1150	1560	15	3-phase	350
N 200/H	1340	500	530	720	200	810	1150	1690	20	3-phase	420
N 300/H	1340	550	700	780	300	860	1340	1750	27	3-phase	500
N 440/H	1340	600	750	1000	450	1000	1450	1820	40	3-phase	1040
N 660/H	1340	600	1100	1000	660	1000	1800	1820	57	3-phase	1260
N 1000/H	1340	800	1000	1250	1000	1450	1850	2000	75	3-phase	2320
N 1500/H	1340	900	1200	1400	1500	1550	2050	2160	110	3-phase	2700
N 2200/H	1340	1000	1400	1600	2200	1650	2250	2360	140	3-phase	3600
N 100/14	1400	400	530	460	100	710	1150	1430	15	3-phase	345
N 150/14	1400	450	530	590	150	760	1150	1560	20	3-phase	400
N 200/14	1400	500	530	720	200	810	1150	1690	22	3-phase	450
N 300/14	1400	550	700	780	300	860	1340	1750	30	3-phase	550
N 440/14	1400	600	750	1000	450	1000	1450	1820	40	3-phase	1320
N 660/14	1400	600	1100	1000	660	1000	1800	1820	57	3-phase	1560
N 1000/14	1400	800	1000	1250	1000	1450	1850	2000	75	3-phase	2500
N 1500/14	1400	900	1200	1400	1500	1550	2050	2160	110	3-phase	3000
N 2200/14	1400	1000	1400	1600	2200	1650	2250	2360	140	3-phase	3900

N 1680/S with customized dimensions for long parts



Chamber furnace with fiber insulation for shorter cycle times



Charging trolley for N 2200

*Please see page 61 for more information about supply voltage

Chamber Furnaces with Wire Heating with Brick Insulation or Fiber Insulation



LH 15/12 with brick insulation



LH 60/12 with scale to measure weight reduction during annealing



Cooling fan in combination with motor-driven exhaust air flap to reduce cooling time

LH 15/12 - LF 120/14

The LH 15/12 - LF 120/14 laboratory furnaces have been trusted for many years as professional chamber furnaces for the laboratory. These furnaces are available with either a robust insulation of light refractory bricks (LH models) or with a combination insulation of refractory bricks in the corners and low heat storage, quickly cooling fiber material (LF models). With a wide variety of optional equipment, these models can be optimally adapted to your processes.

- Tmax 1200 °C, 1300 °C, or 1400 °C
- Five-sided heating for very good temperature uniformity
- Heating elements on support tubes ensure free heat radiation and a long service life
- Protection of bottom heating and flat stacking surface provided by embedded SiC plate in the floor
- LH models: multi-layered, fiber-free insulation of light refractory bricks and special backup insulation

- LF models: high-quality fiber insulation with corner bricks for shorter heating and cooling times
- Door with brick-on-brick seal, hand fitted
- Short heating times due to high installed power
- Side vent with bypass connection for exhaust pipe
- Self-supporting arch for high stability and greatest possible protection against dust
- Quick lock on door
- Freely adjustable air slide intake in furnace floor
- Stand included
- Controls description see page 61

Additional equipment

- Parallel swinging door, pivots away from operator, for opening when hot
- Lift door with electro-mechanic linear drive
- Separate wall-mounting or floor standing cabinet for switchgear



LH 120/12S process box made of quartz glass



LH 216/12SW with scale to measure weight reduction during annealing

- Motor-driven exhaust air flap
- Cooling fan for shorter cycle times
- Protective gas connection to purge with non-flammable protective or reaction gases
- Process box made of quartz glass for very clean atmosphere, quartz glass covered door with lid function
- Manual or automatic gas supply system
- Scale to measure weight reduction during annealing



LH 60/12 with manual lift door and gas supply box for non-flammable protective or reactive gases

Model	Tmax °C	Inner dimensions in mm			Volume in l	Outer dimensions in mm			Connected load kW	Electrical connection*	Weight in kg
		w	d	h		W	D	H			
LH 15/12	1200	250	250	250	15	570	790	1170	5.0	3-phase ¹	150
LH 30/12	1200	320	320	320	30	640	860	1240	7.0	3-phase ¹	170
LH 60/12	1200	400	400	400	60	720	1010	1320	8.0	3-phase	260
LH 120/12	1200	500	500	500	120	820	1110	1420	12.0	3-phase	340
LH 216/12	1200	600	600	600	216	900	1210	1530	20.0	3-phase	400
LH 15/13	1300	250	250	250	15	570	790	1170	7.0	3-phase ¹	150
LH 30/13	1300	320	320	320	30	640	860	1240	8.0	3-phase ¹	170
LH 60/13	1300	400	400	400	60	720	1010	1320	11.0	3-phase	260
LH 120/13	1300	500	500	500	120	820	1110	1420	15.0	3-phase	340
LH 216/13	1300	600	600	600	216	900	1210	1530	22.0	3-phase	400
LH 15/14	1400	250	250	250	15	570	790	1170	8.0	3-phase ¹	150
LH 30/14	1400	320	320	320	30	640	860	1240	10.0	3-phase ¹	170
LH 60/14	1400	400	400	400	60	720	1010	1320	12.0	3-phase	260
LH 120/14	1400	500	500	500	120	820	1110	1420	18.0	3-phase	340
LH 216/14	1400	600	600	600	216	900	1210	1530	26.0	3-phase	400
LF 15/13	1300	250	250	250	15	570	790	1170	7.0	3-phase ¹	130
LF 30/13	1300	320	320	320	30	640	860	1240	8.0	3-phase ¹	150
LF 60/13	1300	400	400	400	60	720	1010	1320	11.0	3-phase	230
LF 120/13	1300	500	500	500	120	820	1110	1420	15.0	3-phase	300
LF 15/14	1400	250	250	250	15	570	790	1170	8.0	3-phase ¹	130
LF 30/14	1400	320	320	320	30	640	860	1240	10.0	3-phase ¹	150
LF 60/14	1400	400	400	400	60	720	1010	1320	12.0	3-phase	230
LF 120/14	1400	500	500	500	120	820	1110	1420	18.0	3-phase	300

¹Heating only between two phases

*Please see page 61 for more information about supply voltage



Parallel swinging door for opening when hot



Gas supply system

Lift-Top or Lift-Bottom Furnaces with Wire Heating up to 1400 °C



H 1000/S

H 125/LB or LT - H 3000/LB or LT

These furnaces were specially developed for cooling complex structures or when the process requires the treatment of warm glass, e.g., the welding process in glass apparatus manufacturing. The wide-opening electro-hydraulically driven hood allows furnace opening even at high temperatures and provides easy access from 3 sides.

- Tmax 1280 °C
- Dual shell housing with rear ventilation for low shell temperatures
- Electrohydraulically driven hood with fixed table
- Five-sided heating from all four sides and from the table provides for a good temperature uniformity
- Heating elements mounted on support tubes provide for free radiation and long service life of the heating wire
- Bottom heating protected by SiC tiles which provide for a level stacking surface

- Multi-layer insulation consisting of lightweight refractory bricks backed by special insulation
- Long-life ceiling design with fiber insulation
- Manual exhaust air flap on the furnace roof
- Over-temperature limiter with manual reset for thermal protection class 2 in accordance with EN 60519-2 as temperature limiter to protect the furnace and load

Additional equipment

- Customized dimensions
- Tmax to 1400 °C
- Lift-bottom furnace version with driven table and fixed hood
- Uncontrolled or controlled cooling system with frequency-controlled cooling fan and motor-driven exhaust air vent



Customized furnace H 1600/14DB



Lift-top furnace H 240/S. Table accessible from four sides for welding quartz glass constructions by vertical and horizontal moveable top-hat



Lift-top system H 245/LTS customized with cooling station and table changing system

- Protective gas connection for purging the furnace with non-flammable protective or reaction gases
- Manual or automatic gas supply systems
- Multi-zone control adapted to the particular furnace provides model for optimal the temperature uniformity
- Commissioning of the furnace with test firing and temperature uniformity measurement (also with load) for the purpose of process optimization
- Additional tables, table changing system, also motor-driven
- Motor-driven exhaust air flap, switchable via the program
- Exhaust air and exhaust gas piping
- Thermal or catalytic exhaust cleaning systems
- Heat recovery systems
- Emergency purging with protective gas
- Process documentation and control with Controltherm MV software package, NTLog and NTGraph for the basic furnace or Nabertherm Control Center (NCC) for monitoring, documentation and control see page 62



Lift-top furnace with alternating table system and protective gas boxes for sintering in non-flammable protective and reaction gas



Measurement setup for determination of temperature uniformity in the useful dimensions of the furnace

Model	Tmax °C	Inner dimensions in mm			Volume in l	Outer dimensions in mm			Connected load kW	Electrical connection*	Weight in kg
		w	d	h		W	D	H			
H 125/LB, LT	1280	800	400	400	125	1330	1280	1900	12	3-phase	1250
H 250/LB, LT	1280	1000	500	500	250	1530	1380	2100	18	3-phase	1400
H 500/LB, LT	1280	1200	600	600	500	1730	1480	2300	36	3-phase	1800
H 1000/LB, LT	1280	1600	800	800	1000	2200	1950	2900	48	3-phase	2800
H 1350/LB, LT	1280	2800	620	780	1360	3690	1700	2750	75	3-phase	3500
H 3000/LB, LT	1280	3000	1000	1000	3000	4000	2100	3200	140	3-phase	6200

*Please see page 61 for more information about supply voltage

Top-Hat Furnaces with SiC Rod Heating



HC 1275 with moveable table



HC 1500



Manually or electrically driven table as option

HC 665 - HC 1500

For temperatures beyond 1350 °C we recommend furnaces with SiC rod heating. The top-hat construction with 4-sides heating provides for exceptional temperature uniformity.

- Tmax of 1400 °C, 1450 °C or 1500 °C
- SiC rod heating on 4 sides of the furnace hood for short cycle times and high temperature uniformity
- High electrical connected power for short cycle times
- Hood insulation made from fiber materials provides for short cycle time and low energy consumption
- Table built from lightweight refractory bricks allows for heavy loads and level stacking surface
- Electro-hydraulic driven hood for vibration-free opening and closing of furnace hood
- Thyristor powered heating
- Controls description see page 61



Heating from 4 sides with SiC rods

Model	Tmax °C	Inner dimensions in mm			Volume in l	Outer dimensions in mm			Connected load kW	Electrical connection*	Weight in kg
		w	d	h		W	D	H			
HC 665	1400	1100	550	1100	665	2350	2050	4000	186	3-phase	3000
HC 1275	1400	850	1000	1500	1275	2100	2500	4400	180	3-phase	4100
HC 1440	1400	840	2400	840	1690	2100	3900	3560	400	3-phase	4700
HC 1500	1400	1000	1000	1500	1500	2250	2500	4400	190	3-phase	5300
HC 1280	1450	800	1600	1000	1280	2050	3100	3900	151	3-phase	4200
HC 700	1500	800	800	1100	700	2050	2300	4000	100	3-phase	3100
HC 1400	1500	800	1600	1100	1400	2050	3100	4000	151	3-phase	4500

*Please see page 61 for more information about supply voltage

Pit-Type and Top-Loading Furnaces, Electrically Heated or Gas-Fired with or without Air Circulation

Our top-loading furnaces are perfectly suited for the heat treatment of longer or heavier components. The furnace is usually charged with a factory crane. Due to their high-performance air recirculation system, the furnaces provide for excellent temperature uniformity up to a maximum temperature of 850 °C. The top-loading furnaces for the temperature range up to 1280 °C provide for very good temperature uniformity due to their five-side heating. Alternatively, these furnaces can also be provided with gas heating. Customized dimensions are designed and produced to accommodate the size and weight of the components to be treated.



- Tmax 260 °C, 450 °C, 600 °C or 850 °C for furnaces with air recirculation
- Tmax 900 °C or 1280 °C for furnaces with radiant heating
- Electrically heated or gas-fired
- Heating from both long sides for furnaces with air recirculation
- Heating from all four sides and the floor with SiC plates in the floor as level stacking support for models to bis 900 °C or 1280 °C
- High-quality insulation, adapted to the specific maximum temperature
- Electrohydraulic opening system of the lid with two-hand operation
- Closable air supply vents in the lower area of the furnace chamber
- Closable exhaust air vents in the lid
- Over-temperature limiter with manual reset for thermal protection class 2 in accordance with EN 60519-2 as temperature limiter to protect the furnace and load

S 5120/GS1 with individual customized dimensions, furnace chamber divided in two sections, split cover



Furnace chamber S 5120/GS with receptacle for an insulating plate in order to divide the furnace chamber

Additional equipment

- Motor-driven exhaust air flaps for faster cooling
- Controlled fan cooling with motor-driven exhaust air flaps
- Multi-zone control of the heating provides for optimum temperature uniformity
- Furnace chamber can be divided in length for short workparts, partitions can be controlled separately
- Customized dimensions
- Customized charging racks
- Designed for Tmax 950 °C, fan blade driven indirectly via a belt to protect the air recirculation motor against over-heating
- Process control and documentation with Controltherm MV software package see page 63



S 4100/S with customized dimensions for sintering of high parts

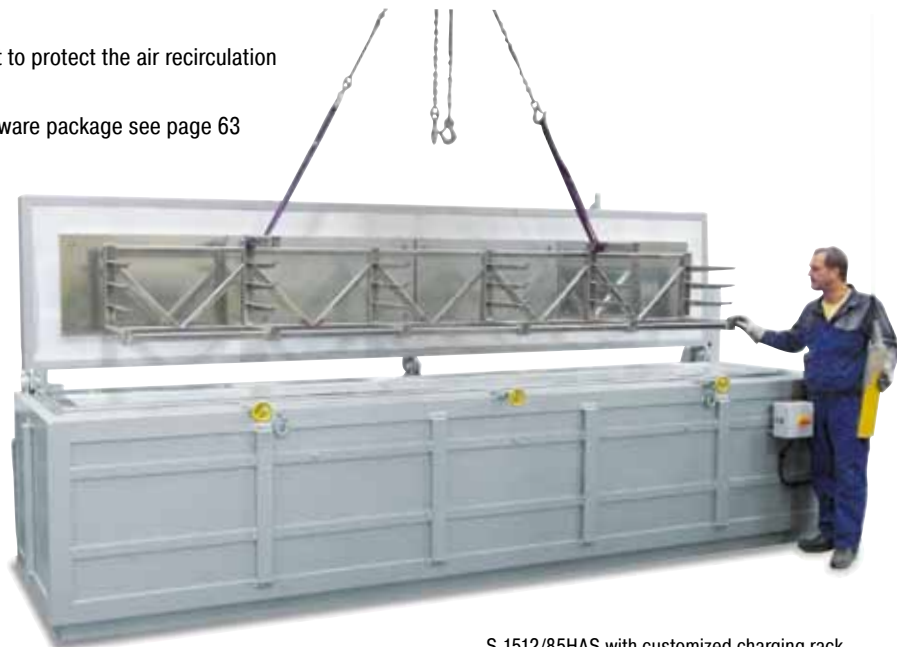

S 1512/85HAS with customized charging rack

High-Temperature Chamber Furnaces with Molybdenum Disilicide Heating Elements with Fiber Insulation up to 1800 °C



HT 160/17 with catalytic afterburning system



HT 16/17

HT 04/16 - HT 450/18

The high-temperature chamber furnaces HT 04/16 - HT 450/18 have proven reliable over many years in laboratory and production. Whether for quartz glass or glass ceramics, for sintering CIM components or for other processes up to a maximum temperature of 1800 °C, these furnaces afford the optimal solution for the sintering process.

High-temperature chamber furnaces can either be insulated with fiber material or lightweight refractory bricks. Furnaces with fiber insulation achieve significantly shorter heating up times because of the low thermal mass. An insulation made of lightweight refractory bricks (see HFL models on page 30), on the other hand, has the advantage of better chemical stability.



Protection of heating elements against mechanical damage

- Tmax 1600 °C, 1750 °C or 1800 °C
- Dual shell housing with fan cooling for low shell temperatures
- Heating from both sides via molybdenum disilicide heating elements
- High-quality fiber insulation backed by special insulation
- Side insulation constructed with tongue and groove blocks provides for low heat loss to the outside
- Long-life roof insulation with special suspension
- Chain-guided parallel swivel door for defined opening and closing of the door
- Labyrinth sealing ensures the least possible temperature loss in the door area
- Specially reinforced furnace floor for accommodating high charge weights for model HT 40 and above
- Exhaust air opening in the furnace roof
- Heating elements switched via SCR's
- Over-temperature limiter with manual reset for thermal protection class 2 in accordance with EN 60519-2 as temperature limiter to protect the furnace and load



HT 160/17 with automatic gas supply system



HT 128/17 S with lift door for opening in hot state

Additional equipment

- Customized dimensions
- Uncontrolled or controlled cooling system with frequency-controlled cooling fan and motor-driven exhaust air flap
- Commissioning of the furnace with test firing and temperature uniformity measurement (also with load) for the purpose of process optimization
- Temperature measurement with thermocouples, types B and type S with automatic pull-out device for precise control results in the low temperature range
- Protection grid in front of the heating elements to prevent mechanical damages see page 30
- Special heating elements for zirconia sintering provide for longer service life with respect to chemical interaction between charge and heating elements
- Protective gas connection to purge with non-flammable protective or reaction gases
- Manual or automatic gas supply system
- Gas supply system in the furnace chamber with ceramic bell jar, protective gas inlet and outlet from below for better sealing when operating with protective gases and/or to prevent from chemical interactions between the load and the insulation or the heating elements
- Parallel swivel door opening upwards, also motor driven
- Bottom insulation made of durable lightweight refractory bricks for heavy charge weights
- Motorized exhaust air flap, switchable via the program
- Emergency purging with protective gas
- Exhaust air and exhaust gas piping
- Thermal or catalytic exhaust cleaning systems
- Process documentation, display and control via HiproSystems control system see page 62



Fresh air injection through perforated injection tubes



High-Temperature Chamber Furnaces with Molybdenum Disilicide Heating Elements with Fiber Insulation up to 1800 °C



HT 1000/17 with two movable door segments and fourside heating for sintering hanging ceramic tubes up to 1700 °C



Inner process hood with gas injection through the furnace bottom protects the furnace chamber against contamination and/or prevents chemical interaction between the charge and heating elements



Gas supply system for non-flammable protective or reaction gases

Model	Tmax °C	Inner dimensions in mm			Volume in l	Outer dimensions in mm			Connected load kW	Electrical connection*	Weight in kg
		w	d	h		W	D	H			
HT 04/16	1600	150	150	150	4	610	470	1400	5.2	3-phase ¹	150
HT 08/16	1600	150	300	150	8	610	610	1400	8.0	3-phase ¹	200
HT 16/16	1600	200	300	260	16	810	700	1490	12.0	3-phase ¹	270
HT 40/16	1600	300	350	350	40	810	710	1610	12.0	3-phase	380
HT 64/16	1600	400	400	400	64	1145	900	1670	18.0	3-phase	550
HT 128/16	1600	400	800	400	128	1020	1250	1700	26.0	3-phase	750
HT 160/16	1600	500	550	550	160	1260	1070	1900	21.0	3-phase	800
HT 276/16	1600	500	1000	550	276	1140	1470	1900	36.0	3-phase	1100
HT 450/16	1600	500	1150	780	450	1200	1620	2060	64.0	3-phase	1500
HT 04/17	1750	150	150	150	4	610	470	1400	5.2	3-phase ¹	150
HT 08/17	1750	150	300	150	8	610	610	1400	8.0	3-phase ¹	200
HT 16/17	1750	200	300	260	16	810	700	1490	12.0	3-phase ¹	270
HT 40/17	1750	300	350	350	40	810	710	1610	12.0	3-phase	380
HT 64/17	1750	400	400	400	64	1145	900	1670	18.0	3-phase	550
HT 128/17	1750	400	800	400	128	1020	1250	1700	26.0	3-phase	750
HT 160/17	1750	500	550	550	160	1260	1070	1900	21.0	3-phase	800
HT 276/17	1750	500	1000	550	276	1140	1470	1900	36.0	3-phase	1100
HT 450/17	1750	500	1150	780	450	1200	1620	2060	64.0	3-phase	1500
HT 04/18	1800	150	150	150	4	610	470	1400	5.2	3-phase ¹	150
HT 08/18	1800	150	300	150	8	610	610	1400	9.0	3-phase ¹	200
HT 16/18	1800	200	300	260	16	810	700	1490	12.0	3-phase ¹	270
HT 40/18	1800	300	350	350	40	810	710	1610	12.0	3-phase	380
HT 64/18	1800	400	400	400	64	1145	900	1670	18.0	3-phase	550
HT 128/18	1800	400	800	400	128	1020	1250	1700	26.0	3-phase	750
HT 160/18	1800	500	550	550	160	1260	1070	1900	21.0	3-phase	800
HT 276/18	1800	500	1000	550	276	1140	1470	1900	36.0	3-phase	1100
HT 450/18	1800	500	1150	780	450	1200	1620	2060	64.0	3-phase	1500

¹Heating only between two phases

*Please see page 61 for more information about supply voltage

High-Temperature Chamber Furnaces with SiC Rod Heating up to 1550 °C



HTC 276/16



HTC 160/16

HTC 16/16 - HTC 450/16

The high-temperature chamber furnaces HTC 16/16 - HTC 450/16 are heated by vertically hung SiC rods, which makes them especially suitable for sintering processes up to a maximum operating temperature of 1550 °C. The basic construction of these furnaces make them comparable with the already familiar models in the HT product line and they can be upgraded with the same additional equipment.

- Tmax 1550 °C
- Dual shell housing with fan cooling for low shell temperatures
- Heating from both sides via vertically mounted SiC rods
- High-quality fiber insulation backed by special insulation
- Side insulation constructed with tongue and groove blocks provides for low heat loss to the outside
- Long-life roof insulation with special suspension
- Chain-guided parallel swivel door for defined opening and closing of the door
- Labyrinth sealing ensures the least possible temperature loss in the door area
- Specially reinforced furnace floor for accommodating high charge weights for model HTC 16 and above
- Exhaust air opening in the furnace roof
- Heating elements switched via SCR's
- Over-temperature limiter with manual reset for thermal protection class 2 in accordance with EN 60519-2 as temperature limiter to protect the furnace and load
- Controls description see page 61



Vertically mounted SiC rods

For additional equipment see models HT 04/16 - HT 450/18



Exhaust-air flap and charge thermocouple including a stand as additional equipment

Model	Tmax °C	Inner dimensions in mm			Volume in l	Outer dimensions in mm			Connected load kW	Electrical connection*	Weight in kg
		w	d	h		W	D	H			
HTC 16/16	1550	200	300	260	16	710	650	1500	12,0	3-phase ¹	270
HTC 40/16	1550	300	350	350	40	810	710	1610	12,0	3-phase	380
HTC 64/16	1550	400	400	400	64	1020	840	1700	18,0	3-phase	550
HTC 128/16	1550	400	800	400	128	1020	1250	1700	26,0	3-phase	750
HTC 160/16	1550	500	550	550	160	1140	1020	1900	21,0	3-phase	800
HTC 276/16	1550	500	1000	550	276	1140	1470	1900	36,0	3-phase	1100
HTC 450/16	1550	500	1150	780	450	1200	1620	2060	64,0	3-phase	1500

¹Heating only between two phases

*Please see page 61 for more information about supply voltage

Chamber Furnaces with Molybdenum Disilicide Heating Elements with Refractory Insulation up to 1700 °C



HFL 160/17 with gas supply system



HFL 295/13 with lift door and transformer in stand, customer-specific design



Protection grid in front of heating elements prevent against mechanical damages

HFL 16/16 - HFL 160/17

The HFL 16/16 HFL 160/17 product line is characterized by its lining with robust light weight refractory bricks. Compared with the fiber-insulated models of the HT product line, these furnaces are recommended when high charge weights have to be sintered. In most cases lightweight refractory brick insulation is also significantly more resistant to gas emissions occurring during heat treatment.

Standard equipment like HT models, except:

- Tmax 1600 °C or 1700 °C
- Sturdy lightweight refractory bricks and special backing insulation
- Furnace floor made of lightweight refractory bricks accommodates high charge weights

Additional equipment like HT models



Gas supply system for non-flammable protective or reaction gases

Model	Tmax °C	Inner dimensions in mm			Volume in l	Outer dimensions in mm			Connected load kW	Electrical connection*	Weight in kg
		w	d	h		W	D	H			
HFL 16/16	1600	200	300	260	16	770	830	1550	12	3-phase ¹	500
HFL 40/16	1600	300	350	350	40	880	880	1710	12	3-phase	660
HFL 64/16	1600	400	400	400	64	980	930	1830	18	3-phase	880
HFL 160/16	1600	500	550	550	160	1090	1080	2030	21	3-phase	1140
HFL 16/17	1700	200	300	260	16	770	830	1550	12	3-phase ¹	530
HFL 40/17	1700	300	350	350	40	880	880	1710	12	3-phase	690
HFL 64/17	1700	400	400	400	64	980	930	1830	18	3-phase	920
HFL 160/17	1700	500	550	550	160	1090	1080	2030	21	3-phase	1190

¹Heating only between two phases

*Please see page 61 for more information about supply voltage

Gas-Fired Chamber Furnaces up to 1600 °C

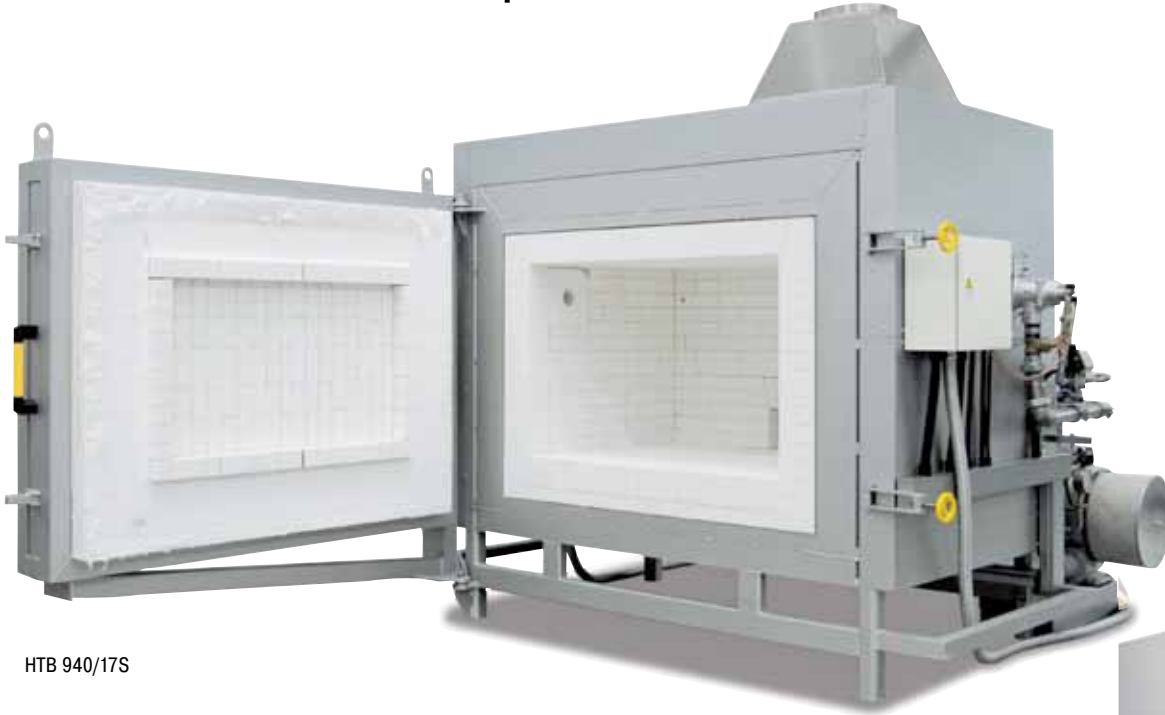

HTB 940/17S

The gas-fired high-temperature furnaces of the HTB product line are specially developed for applications requiring fast heating up ramps. Gas-fired furnaces are preferred also if inflammable gases are produced in large amounts during the process. A large content of the gas emissions are already burned in the furnace chamber, so that downstream equipment like thermal and catalytic exhaust cleaners can accordingly be downsized. The furnaces are insulated with highly heat-resistant and long-life lightweight refractory brick insulation or fiber materials.

- Tmax 1600 °C
- Customized furnace dimensions
- Powerful, sturdy high-speed burners with pulse control and special flame guidance in the furnace chamber provide for good temperature uniformity
- Operation with natural gas, propane or liquified gas
- Fully automatic PLC control of the temperature, including monitoring of the burner function
- Gas fittings according to DVGW (German Technical and Scientific Association for Gas and Water) with flame monitoring and safety valve
- Reduction-resistant fiber insulation with low heat storage provides for short heating and cooling times
- Dual shell housing provides for low outside temperatures
- Exhaust hood with fittings for further discharge of the exhaust gases
- PLC control with touch panel as user interface see page 62



Gas line for natural gas

Additional equipment

- Automatic lambda control to set the furnace atmosphere
- Exhaust air and exhaust gas piping
- Recuperator burners
- Thermal or catalytic exhaust cleaning systems
- Process display and documentation via Nabertherm Control Center (NCC) see page 62



HTB 645/17

Lift-Top and Lift-Bottom Furnaces with Molybdenum Disilicide Heating Elements up to 1800 °C



HT 680/17 LTS2 with table exchange system



HT 64/17 LT

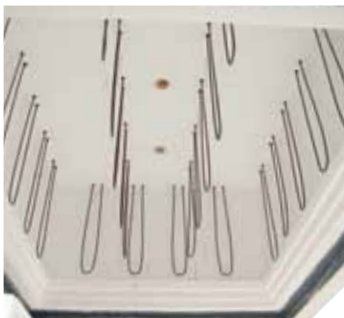

Heat from all sides and between the stack to optimize temperature uniformity

HT 64/14 LB or LT - HT 1440/17 LB or LT

For charging complex settings we recommend lift-top or lift-bottom furnaces. Also small workparts can be conveniently loaded on different layers. Up to an application temperature of 1500 °C the furnaces are heated by SiC rods (HTC models). For sintering temperatures above 1500 °C these furnaces with molybdenum disilicide heating elements (HT models). Possible potential chemical interaction between the charge and the heating method can also affect the selection of heating system.

The basic furnace comes with one table. Depending on the technical requirements are equipped, a lift-top or lift-bottom version will be the choice. The system can be expanded with one or more changeable tables, either manually or electrically driven. Other additional equipment, like controlled cooling systems to short process cycles provide for tailored solution for individual needs.



Heating elements arranged one above the other for tall structures

- Tmax 1400 °C or 1500 °C (HTC models with SiC rod heating)
- Tmax 1600 °C, 1750 °C or 1800 °C (HT models with molybdenum disilicide heating elements)
- Dual shell housing with fan cooling provides for low shell temperatures
- Designed as lift-top furnace with driven hood (LT) or lift-bottom furnace
- Gently running, low-vibration spindle drive or electrohydraulic drive for larger models
- Safe and tight closing of the furnace due to labyrinth seal and sand cup
- Heating from all four sides provides for good temperature uniformity
- High-quality fiber insulation backed by special insulation
- Side insulation constructed with tongue and groove blocks provides for low heat dissipation to the outside
- Long-life roof insulation with special suspension
- Furnace table with special bottom reinforcement to accommodate high charge weights
- Motor-driven exhaust air flap in the furnace roof, switchable at the program
- PLC controls with state-of-the-art touch panel as user interface see page 62
- Over-temperature limiter with manual reset for thermal protection class 2 in accordance with EN 60519-2 as temperature limiter to protect the furnace and load

Additional equipment

- Customized dimensions
- Uncontrolled or controlled cooling system with frequency-controlled cooling fan and motor-driven exhaust air flap
- Commissioning of the furnace with test firing and temperature uniformity measurement (also with load) for the purpose of process optimization
- Temperature measurement with thermocouples, types B and type S with automatic pull-out device for precise control results in the low temperature range
- Heat from all sides and between the stack to optimize temperature uniformity
- Protective gas connection to purge with non-flammable protective or reaction gases
- Manual or automatic gas supply systems
- Gas supply system in the furnace chamber with ceramic bell jar, protective gas inlet and outlet from below for better sealing when operating with protective gases and/or to prevent from chemical interactions between the load and the insulation or the heating elements
- Alternative table changing systems
- Emergency purging with protective gas
- Exhaust air and exhaust gas piping
- Automatic changing system for thermocouple type S/B for precise measurement and control quality at low temperatures
- Thermal or catalytic exhaust cleaning systems
- Process documentation, display and control via HiproSystems control system see page 62



HT 276/18 LTS with two inner process hoods for sintering under non-flammable protective or reaction gases



HT 276/17 LT with manual table changing system



Gas supply system for non-flammable protective or reaction gas

Lift-Top and Lift-Bottom Furnaces with Molybdenum Disilicide Heating Elements up to 1800 °C

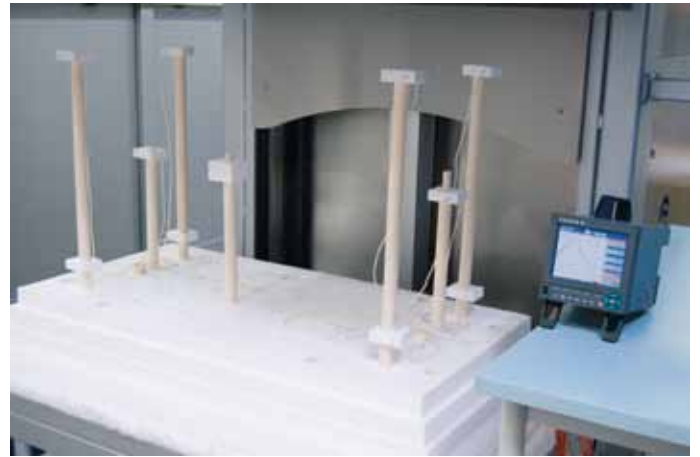

Measurement setup to determine the temperature uniformity in a high-temperature lift-bottom furnace

Combi high-temperature plants HT 1440/17 LBS with catalytic afterburning system for debinding and sintering in one process



Production system consisting of a bogie hearth furnace for debinding and a high-temperature furnace for residual debinding and sintering with shared catalytic afterburning system



High-temperature furnace HT 273/17S with table by transportable fork lift

Model	Tmax °C	Inner dimensions in mm			Volume in l	Outer dimensions in mm			Connected load kW	Electrical connection*	Weight in kg
		w	d	h		W	D	H			
HT 64/16 LB, LT	1600	400	400	400	64	950	1750	2350	36	3-phase	1000
HT 166/16 LB, LT	1600	550	550	550	166	1095	2060	2450	42	3-phase	1600
HT 276/16 LB, LT	1600	1000	500	550	276	1550	2090	2600	50	3-phase	2000
HT 400/16 LB, LT	1600	1200	600	550	400	1750	2200	2600	72	3-phase	2200
HT 1000/16 LB, LT	1600	1000	1000	1000	1000	1550	2600	3200	146	3-phase	3000
HT 1030/16 LB, LT	1600	2200	600	780	1030	2800	2500	3000	163	3-phase	3000
HT 1440/16 LB, LT	1600	1800	800	1000	1440	3000	2800	3700	330	3-phase	4000
HT 64/17 LB, LT	1750	400	400	400	64	950	1750	2350	36	3-phase	1000
HT 166/17 LB, LT	1750	550	550	550	166	1095	2060	2450	42	3-phase	1600
HT 276/17 LB, LT	1750	1000	500	550	276	1550	2090	2600	50	3-phase	2000
HT 400/17 LB, LT	1750	1200	600	550	400	1750	2200	2600	72	3-phase	2200
HT 1000/17 LB, LT	1750	1000	1000	1000	1000	1550	2600	3200	146	3-phase	3000
HT 1030/17 LB, LT	1750	2200	600	780	1030	2800	2500	3000	163	3-phase	3000
HT 1440/17 LB, LT	1750	1800	800	1000	1440	3000	2800	3700	330	3-phase	4000
HT 64/18 LB, LT	1800	400	400	400	64	950	1750	2350	on request	3-phase	1000
HT 166/18 LB, LT	1800	550	550	550	166	1095	2060	2450	on request	3-phase	1600
HT 276/18 LB, LT	1800	1000	500	550	276	1550	2090	2600	on request	3-phase	2000
HT 400/18 LB, LT	1800	1200	600	550	400	1750	2200	2600	on request	3-phase	2200
HT 1000/18 LB, LT	1800	1000	1000	1000	1000	1550	2600	3200	on request	3-phase	3000
HT 1030/18 LB, LT	1800	2200	600	780	1030	2800	2500	3000	on request	3-phase	3000
HT 1440/18 LB, LT	1800	1800	800	1000	1440	3000	2800	3700	on request	3-phase	4000



Customized furnace HT 750/18 LTS

*Please see page 61 for more information about supply voltage

Continuous Furnaces, Electrically Heated or Gas-Fired



Continuous furnace D 700/10000/300/45S with chain conveyor for 950 °C, gas-fired



Service window

Continuous furnaces are the right choice for processes with fixed cycle times such as drying or pre-heating, curing or degassing, etc.. The furnaces are available for various temperatures up to a maximum of 1000 °C. The furnace design depends on the required throughput, the process requirements for heat treatment and the required cycle time. The conveyor technology (e.g. belt, rollers) is tailored to the required working temperature and the geometry of the charge. The conveyor speed and the number of control zones are defined by the process specifications.

Alternative furnace design subject to process specifications:

Conveyor concepts

- Conveyor belt
- Metal conveyor belt with adjusted mesh gauges
- Drive chain

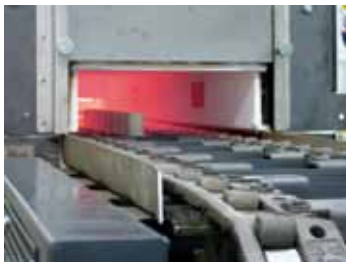

Discharge of D 650/S



Roller conveyor furnace N 650/45 AS for heat treatment in charging trolley



Continuous belt furnace for the heat treatment of bulk materials

- Roller conveyors
- Pusher-type furnace

Heating systems

- Electric heating, radiant or convection
- Direct or indirect gas-firing
- Infrared heating
- Heating with the use of external heat sources

Temperature cycles

- Control of working temperature across the whole length of the furnace, such as for drying or pre-heating
- Automatic control of a process curve applying defined heat-up, dwell and cooling time
- Control of a temperature curve including a final quenching of the charge

Process atmosphere

- In air
- In non-flammable protective or reactive gases such as nitrogen, argon or forming gas
- In flammable protective or reactive gases such as hydrogen incl. the necessary safety technology

Basic configuration criteria

- Conveyor speed
- Temperature uniformity
- Operating temperature
- Process curve
- Charge space width
- Charge weights
- Cycle time or throughput
- Length of charge and discharge zone
- Generated exhaust gases
- Specific industry standards such as AMS, CQI-9, FDA etc.
- Other individual customer requirements



Visualization of process data on the PC



Continuous belt furnace for bulk materials in baskets

Salt Bath Furnaces for Chemical Hardening of Glass, Electrically Heated or Gas-Fired



TS 20/15 - TSB 90/80

Chemical hardening is mostly applied for the solidification of thin glasses with a thickness of up to 3 mm. Chemical pretensioning is recommended because the surface flatness can be maintained. Producers of copy machines, solar modules, microwave devices, measuring instruments as well as companies in the lighting industry, the automotive industry and other users of flat glass need to apply the toughest possible glass in their products. Nearly all glasses containing a large percentage of sodium can be strengthened by means of ion exchange.

TS 40/30, electrically heated

- Tmax 750 °C or 1000 °C in the salt bath
- Safety technology according to EN 60519-2
- Useful for heat treatment of steel
- Bath temperature control
- Electric (TS) all-round heating or gas heating (TSB)
- Removable collar plate made of solid steel
- Insulated swing-a-way lid
- Temperature uniformity up to ΔT 4 K according to DIN 17052-1 in the bath see page 60
- Over-temperature limiter with manual reset in the furnace chamber to prevent dangerous conditions for the furnace or personnel
- Bath control of salt bath and furnace chamber

Crucibles

- Type P: low carbon steel, CrNi plated and corundum coated for carburizing baths up to 950 °C, neutral salt and annealing baths up to 850 °C
- Type C: high alloy CrNi steel for neutral salt and annealing baths up to 1000 °C and for dip brazing of Aluminium

Additional equipment

- Exhaust gas collection at rim for connection to an exhaust system
- Custom dimensions
- Enhanced safety systems for heat treatment of aluminium and magnesium in the salt bath with second over-temperature limiter with manual reset and PLC-bath control with thermocouples in the salt bath and in the furnace chamber



TSB 30/30, gas-fired



TS 30/18 with preheating chamber above the salt bath and crane to dip the charge in

Model	Tmax °C ²	Inner dimensions crucible		Volume in l	Outer dimensions in mm			Connected load kW ¹	Electrical connection*	Weight in kg ¹
		Ø in mm	h in mm		W	D	H			
TS 20/15	750	230	500	20	850	970	800	17	3-phase	650
TS 30/18	750	300	500	30	950	1070	800	20	3-phase	700
TS 40/30	750	400	500	60	1050	1170	800	33	3-phase	750
TS 50/48	750	500	600	110	1150	1270	970	53	3-phase	1000
TS 60/63	750	610	800	220	1250	1370	1170	70	3-phase	1200
TS 70/72	750	700	1000	370	1350	1470	1370	80	3-phase	1500
TS 90/80	750	900	1000	500	1600	1700	1400	100	3-phase	1700
TS, TSB 20/20	1000	230	500	20	850	970	800	22	3-phase	650
TS, TSB 30/30	1000	300	500	30	950	1070	800	33	3-phase	700
TS, TSB 40/40	1000	400	500	60	1050	1170	800	44	3-phase	750
TS, TSB 50/60	1000	500	600	110	1150	1270	970	66	3-phase	1000
TS, TSB 60/72	1000	610	800	220	1250	1370	1170	80	3-phase	1200
TS, TSB 70/90	1000	700	1000	370	1350	1470	1370	100	3-phase	1500
TS, TSB 90/80	1000	900	1000	500	1600	1700	1400	120	3-phase	1700

¹Only for electric version

²Salt bath temperature

*Please see page 61 for more information about supply voltage

Annealing and Hardening Furnaces with Wire Heating, Preheating Furnaces for Molds



N 41/H



N 312

N 7/H - N 641/13

The models N 31/H ff. have been specially developed for preheating of moulds but also for hardening jobs when toolmaking.

- Compact, robust design
- Three-sides heating: from both side walls and floor
- High-quality, free-radiating heating elements mounted on support tubes for longest service life
- Bottom heating protected by heat conducting SiC tiles
- Parallel guided downward swinging door (user protected from heat radiation)
- Stainless steel upper door jamb protects furnace structure when furnace is opened hot
- Exhaust opening in the side of the furnace, or on back wall of furnace in the N 31/H models and higher
- Temperature uniformity up to ΔT 20 K according to DIN 17052-1 see page 60
- Low energy consumption due to multi-layer insulation
- Gas spring dampers provide for easy door opening and closing
- Heat resistant zinc paint for protection of door and door frame (for model N81 and larger)
- Controls description see page 61



N 7/H

Model	Tmax °C	Inner dimensions in mm			Volume in l	Outer dimensions in mm			Connected load/kW	Electrical connection*	Weight in kg
		w	d	h		W	D	H			
N 7/H ¹	1280	250	250	120	7	720	640	510	3.0	1-phase	60
N 11/H ¹	1280	250	350	140	11	720	740	510	3.6	1-phase	70
N 11/HR ¹	1280	250	350	140	11	720	740	510	5.5	3-phase ²	70
N 17/HR ¹	1280	250	500	140	17	720	890	510	6.4	3-phase ²	90
N 31/H	1280	350	350	250	30	840	1010	1320	15.0	3-phase	210
N 41/H	1280	350	500	250	40	840	1160	1320	15.0	3-phase	260
N 61/H	1280	350	750	250	60	840	1410	1320	20.0	3-phase	400
N 87/H	1280	350	1000	250	60	840	1660	1320	25.0	3-phase	480
N 81	1200	500	750	250	80	1140	1900	1790	20.0	3-phase	820
N 161	1200	550	750	400	160	1180	1930	1980	30.0	3-phase	910
N 321	1200	750	1100	400	320	1400	2270	2040	47.0	3-phase	1300
N 641	1200	1000	1300	500	640	1690	2670	2240	70.0	3-phase	2100
N 81/13	1300	500	750	250	80	1220	1960	1840	22.0	3-phase	900
N 161/13	1300	550	750	400	160	1260	1990	2030	35.0	3-phase	1000
N 321/13	1300	750	1100	400	320	1480	2330	2090	60.0	3-phase	1500
N 641/13	1300	1000	1300	500	640	1770	2730	2290	80.0	3-phase	2500

¹Table-top model

²Heating only between two phases

*Please see page 61 for more information about supply voltage



Production moulds for beer glasses

Fusing Furnaces with Wire Heating with fixed Table



GF 75



GF 240



"Combing" in a GF 240



Exhaust air flap as additional equipment

GF 75 - GF 1425

The furnaces in the GF75 - GF 1425 product line were conceived for professional glass artists. The heating elements, closely arranged, protected in quartz tubes, ensure a very high degree of temperature uniformity during fusing or during bending across the whole table surface. The optimized insulation, made of non-classified fibrous material in the furnace hood and robust lightweight refractory bricks in the furnace floor allow clean and safe operation. High current connection capacities assure that the furnace can be rapidly warmed up. The complete firing sequence is controlled by the intuitively operated Controller P300.

- Tmax 950 °C
- Heating element, protected in quartz tubes
- High current connection capacities for short warm-up times and energy-saving way of working
- Arranged closely beside each other on the top, heating elements ensure direct and uniform radiation of the glass
- Level table surface with insulation made of robust lightweight refractory bricks and marked charge surface
- Hood insulation made of non-classified ceramic fibers for rapid warming up and cooling down
- Solid state relays provide for low-noise operation
- Fast power switching for precise temperature uniformity
- Type "K" (NiCr-Ni) thermocouple inside the furnace chamber for precise temperature measurement
- Double-wall, adjustable hood made of structured stainless steel with lid made of perforated sheet metal
- Attractive and professional design enhances your image
- Hood very easy to open and close, supported by high-quality compressed-gas springs
- Adjustable, large quick-release fasteners - can be used while working in gloves
- Large handles on the left and right side of the hood for opening and closing the furnace
- Angled sight ports with plugs let you see the progress of your work and cool quickly
- Robust base on rollers (two of them can be locked down) with tray for glass and tools
- Controller integrated to save space on the right side of the furnace
- Other sizes or custom designs available on request



GF 600

- Comfortable charging height with base of 870 mm
- Exhaust air flap on hood for rapid cooling as additional equipment
- Controls description see page 61

Model	Tmax °C	Inner dimensions in mm			Floor space in m ²	Outer dimensions in mm			Connected load kW	Electrical connection*	Weight in kg
		w	d	h		W	D	H ³			
GF 75	950	620	620	310	0.38	1100	965	1310	3.6	1-phase	180
GF 75 R	950	620	620	310	0.38	1100	965	1310	5.5	3-phase ¹	180
GF 190 LE	950	1010	620	400	0.62	1480	965	1400	6.0	1-phase ²	245
GF 190	950	1010	620	400	0.62	1480	965	1400	6.4	3-phase ¹	245
GF 240	950	1010	810	400	0.81	1480	1155	1400	11.0	3-phase	250
GF 380	950	1210	1100	400	1.33	1680	1465	1400	15.0	3-phase	450
GF 420	950	1660	950	400	1.57	2130	1315	1400	18.0	3-phase	500
GF 520	950	1210	1160	400	1.40	1680	1525	1400	15.0	3-phase	550
GF 600	950	2010	1010	400	2.03	2480	1375	1400	22.0	3-phase	600
GF 920	950	2110	1160	400	2.44	2580	1525	1400	26.0	3-phase	850
GF 1050	950	2310	1210	400	2.79	2780	1575	1400	32.0	3-phase	1050
GF 1425	950	2510	1510	400	3.79	2880	1875	1400	32.0	3-phase	1250

¹Heating only between two phases

²Fusing of 32 A if connected to 230 V

³Base included

*Please see page 61 for more information about supply voltage

Fusing Furnaces with Wire Heating with movable Table

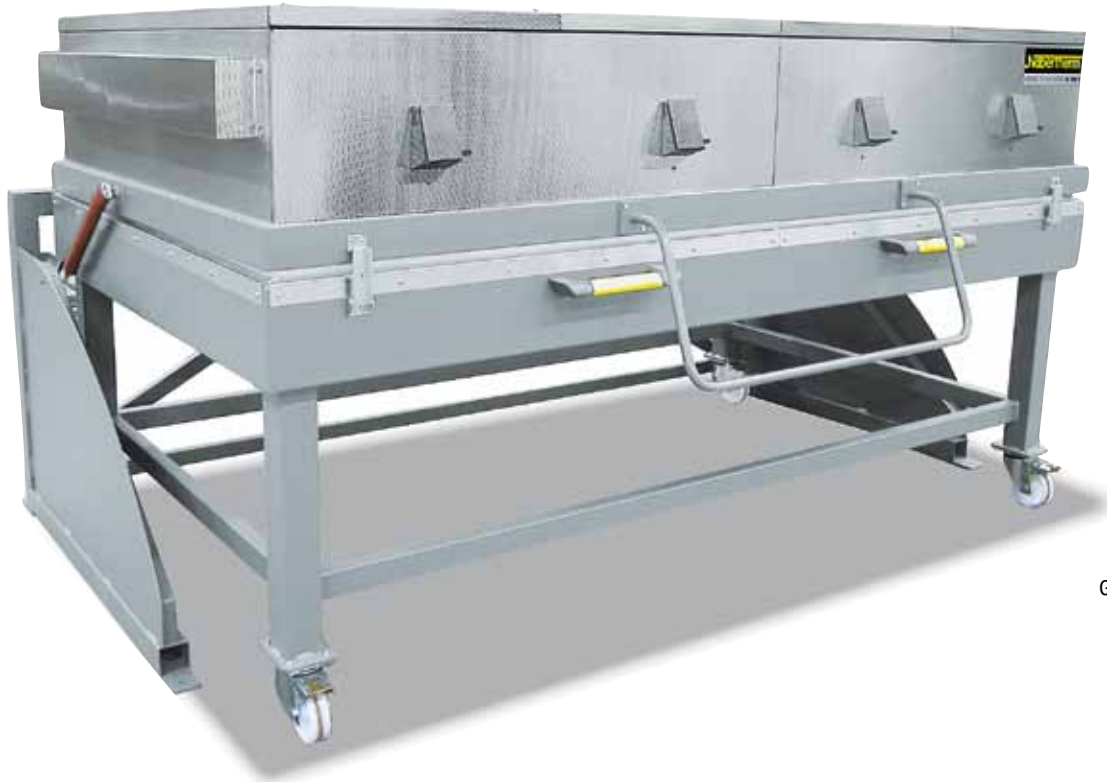

GFM 1050



Locking device provides for defined hood opening in different positions and accelerated cooling

GFM 420 - GFM 1050

The GFM product line was developed to meet the special requirements of production. For different applications different table depths can be supplied. Standard is a table for fusing. Various tables and tubs with different heights and numerous additional equipments are available as system add-ons. Especially economical is the alternating table system, in which one table is loaded while the other one is in the furnace.

- Tmax 950 °C
- Infrared heated in hood which is attached to stand
- Delivered with one table
- Table on wheels, freely movable
- Level table surface with insulation made of robust lightweight refractory bricks and marked charge surface
- Comfortable charging height with base of 870 mm
- Heating element, protected in quartz tubes
- High current connection capacities for short warm-up times and energy-saving way of working
- Arranged closely beside each other on the top, heating elements ensure direct and uniform radiation of the glass
- Solid state relays provide for low-noise operation
- NiCr-Ni thermocouple inside the furnace for precise temperature measurement
- Dual shell housing, adjustable hood made of structured stainless steel with lid made of perforated sheet metal
- Hood insulation made of non-classified ceramic fibers for rapid warming up and cooling down
- Attractive design and solid construction
- Hood very easy to open and close, supported by high-quality compressed-gas springs
- Adjustable, large quick-release fasteners - can be used while working in gloves
- Large handles on the left and right side of the hood for opening and closing the furnace
- Supply air and glass inspection ports with insulated doors, viewing window as an additional equipment
- Controls description see page 61



Flap with inspection glass as additional equipment for easy observation of the glass.



GFM 600 with changeable table system for shorter process times

Additional equipment for fusing furnaces GF and GFM

- Motor-driven lid opening for faster cooling, programmable via the extra controller function, for models GF 380 and/or GFM 380 up
- Bottom heating for uniform through heating of large objects as additional equipment
- Cooling fan for accelerated cooling with closed lid
- Additional tables for extension of the furnace system
- Exchangeable table system for utilization of the residual heat of the furnace. Cycle times can be shortened by changing the tables in warm condition (depending on the ability of the respective glass to cope with temperature change)
- Exhaust air flap on hood for rapid cooling
- Air inlet flap with window for observing the glass



GFM 1050 with electrically driven exhaust air flaps and locking mechanism for the cover



Locking device provides for defined lid opening in different positions and accelerated cooling

Model	Tmax °C	Inner dimensions in mm			Floor space in m ²	Outer dimensions in mm			Connected load kW	Electrical connection*	Weight in kg
		w	d	h		W	D	H			
GFM 420	950	1650	850	380	1.40	2400	1480	1400	18	3-phase	410
GFM 520	950	1200	1150	380	1.38	1950	1780	1400	15	3-phase	430
GFM 600	950	2000	1000	380	2.00	2750	1630	1400	22	3-phase	610
GFM 920	950	2100	1150	380	2.42	2850	1780	1400	26	3-phase	740
GFM 1050	950	2300	1200	380	2.76	3050	1830	1400	32	3-phase	860

*Please see page 61 for more information about supply voltage

Tub Furnaces with Wire Heating



GW 1660

GW 830 - GW 8000

For slumping and bending of complex glass parts, e.g. glass furniture, shower cabins, etc., tub furnaces are the right choice. Full coverage heating: from the lid, all 4 sides and the tub bottom. Due to the modular system additional tubs in customized dimensions can be provided.

- Tmax 900 °C
- Full coverage heating: from lid, all 4 sides and bottom
- 3-zone temperature control from top to bottom for optimal temperature uniformity
- Heating elements mounted on ceramic support tubes for free heat radiation and long service life
- Bottom heating covered by SiC tiles
- Hood insulated with high-quality fiber materials
- Tub bottom insulated with multi-layer of insulation, lightweight refractory bricks on the hot face
- Hinged hood as standard version
- Gas operated dampers provide for easy hood opening
- Manually operated exhaust air flaps
- Tub on wheels can be pulled out manually
- Rails on floor for perfect tub guidance included
- Controls description see page 61



Indirect cooling behind the insulation for reduction of turbulences in the furnace chamber

Additional equipment

- Furnaces tailor-made to individual customer measurements
- Interchangeable table system on rails, electrically driven on request
- Electro-hydraulically driven hood instead of hinged cover
- Tub insert to elevate bottom height, in order to use the furnace for glass fusing applications (in this product version the tub heating can be switched off)



Bottom heating covered by SiC tiles to create level stacking support

Model	Tmax °C	Inner dimensions in mm			Volume in L	Outer dimensions in mm			Connected load kW	Electrical connection*	Weight in kg
		w	d	h		W	D	H			
GW 830	900	1200	1150	600	830	2140	1980	1250	36	3phase	820
GW 840	900	1650	850	600	840	2590	1680	1250	36	3phase	980
GW 1200	900	2000	1000	600	1200	2940	1830	1250	40	3phase	1210
GW 1500	900	2100	1150	600	1450	3040	1980	1250	70	3phase	1420
GW 1660	900	2300	1200	600	1660	3240	2030	1250	80	3phase	1780
GW 2200	900	2300	1200	800	2200	3240	2030	1400	90	3phase	2160
GW 8000	900	3700	2700	800	8000	9000	4750	1400	180	3phase	2980

*Please see page 61 for more information about supply voltage



Top-hat furnace GW 2208/S tailor-made, electro-hydraulically driven hood, tub can be pulled out on rails

- Automatic lid opening for faster cooling, programmable via the controller extra function
- Motor-driven exhaust air flaps in the hood for preselected cooling
- Powerful cooling system

An efficient fan system, mounted to the furnace, cools the dual shell housing from the back. This system shortens cooling times by up to 50 % subject to cycles and charge. Direct contact between the cooling air and charge, hence turbulences in the firing chamber are avoided, protecting the glass from any damage.



Automatic lid opening via electromechanical spindle

- Interchangeable table system running on rails
To shorten process times and optimise operational capacity, two or more furnace tubs, placed alternately under the hood, can be used. An automatic tub changing system is also available on request.



GW 2200



Motor-driven exhaust air flaps as additional equipment



GW 1660 with charge

Top-Hat Furnaces with Wire Heating with Table



Furnace system HG 5208/S with two tables for bending and slumping of glass

HG 750 - HG 7608/S

Nabertherm markets this range of top-hat furnaces for bending and slumping of large glass parts. The standard furnace is equipped with one table running on rails which can be pulled out for easy charging. As accessory an additional table can be integrated, which is charged while the other table is in the furnace. The furnace is heated from the ceiling and from the table.



- Tmax 900 °C
- Heating from lid and table
- 3-zone temperature control (lid-inner circular element, lid-outer circular element, table) for optimal temperature uniformity
- Table heating can be switched-off for fusing
- Heating elements on supporting tubes provide for long service life
- Table heating elements covered by SiC tiles for level stacking support
- Hood insulated with high-quality fiber materials
- Table insulated with multi-layer resistant, lightweight refractory bricks
- Top-hat to be opened by overhead crane in floor shop
- Protection guides for easy hood opening and closing

HG 2000, standard version



Top-hat furnace HG 1196/S with customized specifications, hood and table heating; table heating can be switched-off during fusing

- Manually-operated exhaust air flap
- Furnace table on fixed chassis for user-friendly charging height (800 mm)
- Controls description see page 61

Additional equipment

- Tailor-made furnaces in customized dimensions
- Hood side heating in case of high hood dimensions
- Design without table heating or with disengageable table heating for fusing
- Interchangeable table system on rails, electrically powered on request
- Electro-hydraulically driven hood
- Cooling system
- Table on wheels for free movement
- Motor-driven exhaust air flaps



Motor-driven exhaust air flaps as additional equipment

Model	Tmax °C	Inner dimensions in mm			Floor space in m ²	Outer dimensions in mm			Connected load kW	Electrical connection*	Weight in kg
		w	d	h		W	D	H			
HG 750	900	2100	1200	300	2,52	2550	1800	1350	35	3-phase	1200
HG 1000	900	1750	1000	550	1,75	2200	1450	1600	33	3-phase	1500
HG 1500	900	2100	1250	550	2,63	2550	1700	1600	44	3-phase	2000
HG 1800	900	2450	1850	400	4,35	2950	2350	1600	45	3-phase	2500
HG 2000	900	2450	1500	550	3,68	2900	1950	1600	55	3-phase	2500
HG 2640	900	3000	2200	400	6,60	3500	2700	1450	75	3-phase	3400
HG 3000	900	3500	2200	400	7,70	4000	2800	1600	75	3-phase	3800
HG 4800	900	5500	2100	400	11,55	6000	2700	1600	90	3-phase	4500
HG 5208/S	900	3100	2100	800	6,51	3990	2590	3140	110	3-phase	5000
HG 7608/S	900	3800	2500	800	9,50	4690	2990	3140	143	3-phase	7000

*Please see page 61 for more information about supply voltage



Heating elements in furnace hood

Hot-Wall Retort Furnaces up to 1100 °C



NR 75/06 with automatic gas injection and touch panel H 3700



NR 17/06 with gas supply system



Inside heating in models NRA ../06

NRA 17/06 - NRA 1000/11

These gastight retort furnaces are equipped with direct or indirect heating depending on temperature. They are perfectly suited for various heat treatment processes requiring a defined protective or a reaction gas atmosphere. These compact models can also be laid out for heat treatment under vacuum up to 600 °C. The furnace chamber consists of a gas tight retort with water cooling around the door to protect the special sealing. Equipped with the corresponding safety technology, retort furnaces are also suitable for applications under reaction gases, such as hydrogen or, in combination with the IDB package, for inert debinding or for pyrolysis processes.

Different model versions are available depending on the temperature range required for the process:

Models NRA ../06 with Tmax 650 °C

- Heating elements located inside the retort
- Temperature uniformity up to ΔT 6 K inside the working chamber from 100 °C - 600 °C see page 60
- Retort made of 1.4571
- Gas circulation fan in the back of the retort provides for optimal temperature uniformity

Models NRA ../09 with Tmax 950 °C

- Outside heating with heating elements surrounding the retort as well as an additional door heater
- Temperature uniformity up to ΔT 6 K inside the working chamber from 200 °C - 900 °C see page 60
- Retort made of 1.4841
- Fan in the back of the retort provides for optimal temperature uniformity

Models NR ../11 with Tmax 1100 °C

- Outside heating with heating elements surrounding the retort as well as an additional door heater
- Temperature uniformity up to ΔT 10 K inside the working chamber from 200 °C - 1050 °C see page 60
- Retort made of 1.4841



Heating from outside around the retort in models NRA ../09 and NR ../11



Customized furnace NRA 480/04

Basic version

- Compact housing in frame design with removable stainless steel sheets
- Controls and gas supply integrated in the furnace housing
- Welded charging supports in the retort or air-baffle box in the furnace with air circulation
- Swivel door hinged on right side with open cooling water system
- Multi-zone control for 950 °C and 1100 °C version, separated by furnace chamber and door. Depending on furnace chamber additionally subdivided into one or several heating zones
- Temperature control as charge control with temperature measurement inside and outside the retort
- Gas supply system for one non-flammable protective or reaction gas with flow meter and solenoid valve, switchable via the control system
- Operation under vacuum up to 600 °C with optional single-stage rotary vane pump
- Port for vacuum pump for cold evacuation
- PLC controls with touch panel H 700 for data input (resp. P 300 for 650 °C-version) see page 82

Additional equipment

- Upgrade for other non-flammable gases
- Automatic gas injection, including MFC flow controller for alternating volume flow, PLC controlled with touch panel H 3700
- Vacuum pump for evacuating of the retort up to 600 °C, attainable vacuum up to 10^{-5} mbar subject to selected pump
- Cooling system for shortening process times
- Heat exchanger with closed-loop cooling water circuit for door cooling
- Measuring device for residual oxygen content



NRA 50/09 H2



Vacuum pump for cold evacuation of the retort

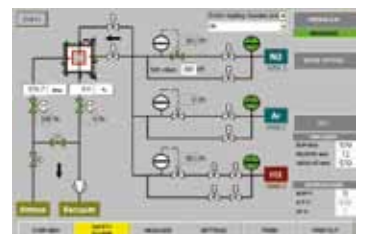

Touchpanel H 3700 for automatic version



NR 200/11 H₂ for heat treatment under hydrogen



Charging of the NR 300/06 furnace with a pallet truck

H₂ Version for Operation under Hydrogen

When hydrogen is used as a process gas, the furnace is additionally equipped with the required safety technology. Only certified and industry proven safety sensors are used. The furnace is controlled by a fail-safe PLC control system (S7- 300F/safety controller).



Bayonet quick-lock for the retort, also with electric drive as additional equipment

- H₂ supply at controlled overpressure of 50 mbar relative
- Certified safety concept
- PLC controls with graphic touch panel H 3700 for data input
- Redundant gas inlet valves for hydrogen
- Monitored pre-pressures of all process gases
- Bypass for safe flushing of furnace chamber with inert gas
- Torch for thermal afterburning of exhaust gases
- Emergency flood container for purging the furnace in case of failure



Parallel guided door to open the hot furnace as additional equipment

IDB Version for Debinding under Non-flammable Protective Gases or for Pyrolysis Processes

The retort furnaces of the NR and NRA product line are perfectly suited for debinding under non-flammable protective gases or for pyrolysis processes. The IDB version of the furnaces implements a safety concept by controlled purging the furnace chamber with a protective gas. Exhaust gases are burned in an exhaust torch. Both the purging and the torch function are monitored to ensure a safe operation.

- Process control under monitored and controlled overpressure of 50 mbar relative
- Certified safety concept
- PLC controls with graphic touch panel H 1700 for data input
- Monitored gas pre-pressure of the process gas
- Bypass for safe flushing of furnace chamber with inert gas
- Torch for thermal afterburning of exhaust gases



Blueing of drills in water steam atmosphere in a furnace of the NRA range

Model	Tmax °C	Model	Tmax °C	Working chamber dimensions in mm			Useful volume in l	Electrical connection*
				w	d	h		
NRA 17/..	650 or 950	NR 17/11	1100	225	350	225	17	3-phase
NRA 25/..	650 or 950	NR 25/11	1100	225	500	225	25	3-phase
NRA 50/..	650 or 950	NR 50/11	1100	325	475	325	50	3-phase
NRA 75/..	650 or 950	NR 75/11	1100	325	700	325	75	3-phase
NRA 150/..	650 or 950	NR 150/11	1100	450	750	450	150	3-phase
NRA 200/..	650 or 950	NR 200/11	1100	450	1000	450	200	3-phase
NRA 300/..	650 or 950	NR 300/11	1100	570	900	570	300	3-phase
NRA 400/..	650 or 950	NR 400/11	1100	570	1250	570	400	3-phase
NRA 500/..	650 or 950	NR 500/11	1100	720	1000	720	500	3-phase
NRA 700/..	650 or 950	NR 700/11	1100	720	1350	720	700	3-phase
NRA 1000/..	650 or 950	NR 1000/11	1100	870	1350	870	1000	3-phase

*Please see page 61 for more information about supply voltage

SRA 17/.. - SR 1500

The retort furnaces SR and SRA (with gas circulation) are designed for operation with non-flammable or flammable protective or reaction gases. The furnace is loaded from above by crane or other lifting equipment provided by the customer. In this way, even large charge weights can be loaded into the furnace chamber.

Depending on the temperature range in which the furnace be used, the following models are available:

Models SR .../11 with Tmax 1100 °C

- Heating from all sides outside the retort
- Temperature uniformity up to ΔT 14 K according to DIN 17052-1 within the working chamber of 500 °C - 1100 °C see page 60
- Retort made of 1.4841
- Top down multi-zone control of the furnace heating

Models SRA/09 with Tmax 950 °C

Design like models SR.../11 with following differences:

- Atmosphere circulation with powerful fan in the furnace lid provides for temperature uniformity up to ΔT 8 K according to DIN 17052-1 within the working chamber of 200 °C - 900 °C see page 60

Models SRA/06 with Tmax 600 °C

Design like models SRA.../09 with following differences:

- Heating inside the retort
- Temperature uniformity up to ΔT 14 K according to DIN 17052-1 within the working chamber of 100 °C - 600 °C see page 60
- Single-zone control
- Retort made of 1.4841

Standard Equipment (all models)

Design like standard equipment of models NR and NRA with following differences:

- Charging from above with crane or other lifting equipment from customer
- Hinged lid with opening to the side

Additional equipment, H₂ version or IDB version see models NR and NRA

Model	Tmax °C	Inner dimensions of alloy retort		Volume in l	Outer dimensions in mm			Connected load/kW		Electrical connection*	Weight in kg
		ø in mm	h in mm		W	D	H	600 °C	950 °C		
SRA 17/..	600 or 950	250	350	17	1300	1700	1800	15	20	3-phase	600
SRA 25/..		250	500	25	1300	1900	1800	20	25	3-phase	800
SRA 50/..		400	450	50	1400	2000	1800	36	35	3-phase	1300
SRA 100/..		400	800	100	1400	2000	2100	45	65	3-phase	1500
SRA 200/..		600	700	200	1600	2200	2200	60	90	3-phase	2100
SRA 300/..		600	1000	300	1600	2200	2500	75	120	3-phase	2400
SRA 500/..		800	1000	500	1800	2400	2700	70	170	3-phase	2800
SRA 600/..		800	1200	600	1800	2400	2900	90	190	3-phase	3000
SRA 800/..		1000	1000	800	2000	2600	2800	105	220	3-phase	3100
SRA 1000/..		1000	1300	1000	2000	2600	3100	120	250	3-phase	3300
SRA 1500/..	1200	1300	1500	2200	2800	3300	150	300	3-phase	3500	
SR 17/11	1100	250	350	17	1300	1700	1800	22		3-phase	600
SR 25/11	1100	250	500	25	1300	1900	1800	27		3-phase	800
SR 50/11	1100	400	450	50	1400	2000	1800	40		3-phase	1300
SR 100/11	1100	400	800	100	1400	2000	2100	73		3-phase	1500
SR 200/11	1100	600	700	200	1600	2200	2200	98		3-phase	2100
SR 300/11	1100	600	1000	300	1600	2200	2500	132		3-phase	2400
SR 500/11	1100	800	1000	500	1800	2400	2700	182		3-phase	2800
SR 600/11	1100	800	1200	600	1800	2400	2900	205		3-phase	3000
SR 800/11	1100	1000	1000	800	2000	2600	2800	235		3-phase	3100
SR 1000/11	1100	1000	1300	1000	2000	2600	3100	268		3-phase	3300
SR 1500/11	1100	1200	1300	1500	2200	2800	3300	315		3-phase	3500

*Please see page 61 for more information about supply voltage



SRA 200/09



Retort furnace SRA 300/09

Cold-Wall Retort Furnaces up to 2400 °C



VHT 500/22-GR H₂ with extension package for operation under vacuum and CFC-process box



VHT 8/22-KE with fiber insulation and molybdenum disilicide heating elements

VHT 8/18-GR - VHT 100/18-KE

The compact furnaces of the VHT product line are available as electrically heated chamber furnaces with graphite, molybdenum or MoSi₂ heating. A wide variety of heating designs as well as a complete range of accessories provide for optimal furnace configurations even for sophisticated applications.

The vacuum-tight retort allows heat treatment processes either in protective and reaction gas atmospheres or in a vacuum, subject to the individual furnace specs to 10⁻⁵ mbar. The basic furnace is suited for operation with non-flammable protective or reactive gases or under vacuum.

The H₂ version provides for operation under hydrogen or other flammable gases. Key of the specification up is a certified safety package providing for a safe operation at all times and triggers an appropriate emergency program in case of failure.

If you intend to debind in an inert atmosphere, we recommend the use of a process box. The exhaust gases are vented directly from the box to the exhaust gas torch.

Alternative Heating Specifications

The following heating systems are available for the different application temperatures:

VHT ../GR with Graphite Insulation and Heating

- Suitable for processes under protective and reaction gases or under vacuum
- Tmax 1800 °C or 2200 °C
- Max. vacuum up to 10⁻² mbar depending on pump type used
- Graphite felt insulation
- Temperature measurement using type B thermocouple (version to 1800 °C)
- Temperature measurement using optical pyrometer (version to 2200 °C)



Heat treatment of copper bars under hydrogen in VHT 08/16 MO

VHT ../MO or ../W with Molybdenum or Tungsten Heating

- Suitable for high-purity processes under protective and reaction gases or under high vacuum
- Tmax 1200 °C, 1600 °C or 1800 °C (see table)
- Max. vacuum up to 5×10^{-5} mbar depending on pump type used
- Insulation made of Molybdenum steel sheets
- Temperature measurement with thermocouple, type S for models with 1200 °C
- Temperature measurement with thermocouple, type B for models with 1600 °C and 1800 °C

VHT ../KE with Fiber Insulation and Heating through Molybdenum Disilicide Heating Elements

- Suitable for processes under protective and reaction gases, in air or under vacuum
- Tmax 1800 °C
- Max. vacuum up to 10^{-2} mbar (up to 1300 °C) depending on pump type
- Insulation made of high purity aluminum oxide fiber
- Temperature measurement by thermocouple type B

	VHT/GR	VHT ...-16/MO	VHT ...-18/W	VHT ...-18/KE
Inert gas	✓	✓	✓	✓
Air	to 400 °C	-	-	✓
Hydrogen	✓	✓	✓	✓ ¹
Rough vacuum and fine vacuum ($>10^{-3}$ mbar)	✓	✓	✓	✓ ²
High vacuum ($<10^{-5}$ mbar)	-	✓	✓	-
Oxygen	-	-	-	✓

¹up to 1400

²depending on Tmax

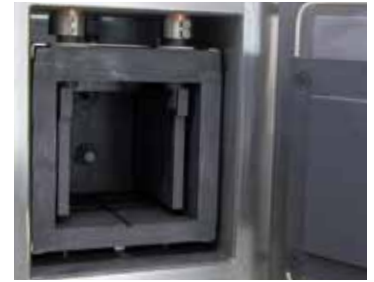

Graphite heating chamber



Molybdenum or tungsten heating chamber

Standard Equipment for all Models

Basic version

- Standard furnace sizes 8, 40 and 100 liters
- A water-cooled stainless steel process reactor sealed with temperature-resistant o-rings
- Frame made of stable steel profiles, easy to service due to easily removable stainless steel panels
- Housing of the VHT 8 model on castors for easy repositioning of furnace
- Cooling water manifold with manual stopcocks in supply and return lines, automatic flowmeter monitoring, openloop cooling water system
- Adjustable cooling water circuits with flowmeter and temperature indicator and overtemperature fuses
- Switchgear and controller integrated in furnace housing
- H 700 PLC control with clearly laid out 5.7" touchpanel control for program entry and display, 10 programs each with 20 segments
- Over-temperature limiter with manual reset for thermal protection class in accordance with EN 60519-2
- Manual operation of the process gas and vacuum functions
- Manual gas supply for one process gas (N₂ or Ar) with adjustable flow
- Bypass with manual valve for rapid filling or flooding of furnace chamber
- Manual gas outlet with overflow valve (20 mbar relative)
- Single-stage rotary vane pump with ball valve for pre-evacuating and heat treatment in a rough vacuum to 5 mbar
- Pressure gauge for visual pressure monitoring

Additional equipment

- Tmax 2400 °C
- Housing, optionally divisible, for passing through narrow door frames (VHT 08)
- Manual gas supply for second process gas (N₂ or Ar) with adjustable flow and bypass
- Inner process box made of molybdenum or CFC, especially recommended for debinding processes. The box is installed in the furnace with direct gas inlet and outlet and provides for better temperature uniformity. Due to a change in gas supply direction after debinding a clean process atmosphere for sintering is achieved.

Model	Inner dimensions of retort in mm			Volume in l
	w	d	h	
VHT 8/..	120	210	150	4
VHT 40/..	280	430	250	30
VHT 100/..	430	530	400	91

- Charge thermocouple with display
- Two-stage rotary vane pump with ball valve for pre-evacuating and heat-treating in a vacuum to 10^{-2} mbar



Ceramic fiber insulation



Thermocouple, type S with automatic pull-out device for precise control results in the low temperature range



VHT 40/22 GR with motor-driven lift door



VHT 40/16MOH₂

Continuation of additional equipment

- Temperature measurement at 2200 °C models with pyrometer and thermocouple, type S with automatic pull-out device for precise control results in the low temperature range (VHT 40 and larger)
- Turbo molecular pump with slide valve for pre-evacuation and for heat treatment in a vacuum to 10⁻⁵ mbar including electric pressure transducer and booster pump (only VHT.../MO)
- Heat exchanger with closed-loop cooling water circuit
- Automation package with graphic touch panel H 3700
 - 12" graphic touch panel H 3700
 - Input of all process data like temperatures, heating rates, gas injection, vacuum at the touch panel
 - Display of all process-relevant data on a process control diagram
 - Automatic gas supply for one process gas (N₂, argon or forming gas) with adjustable flow
 - Bypass for flooding and filling the chamber with process gas controlled by the program
 - Automatic pre- and post programs, including leak test for safe furnace operation
 - Automatic gas outlet with bellows valve and overflow valve (20 mbar)
 - Transducer for absolute and relative pressure
- MFC flow controller for alternating volume flow and generation of gas mixtures with second process gas (only with automation package)
- Partial pressure operation: protective gas flushing at controlled underpressure (only with automation package)
- PC control via NCC with corresponding optional documentation and connection to customer PC networks



Turbo-molecular pump



Single-stage rotary vane pump for heat treatment in a rough vacuum to 20 mbar



Two-stage rotary vane pump for heat treatment in a vacuum to 10⁻² mbar



Turbo-molecular pump with booster pump for heat treatment in a vacuum to 10⁻⁵ mbar

H₂ Version VHT.../MO-H₂ or VHT.../GR-H₂ for Operation with Hydrogen or other Reaction Gases

In the H₂ version the furnaces of the VHT.../MO or VHT.../GR product line can be operated under hydrogen or other reaction gases. For these applications, the systems are additionally equipped with the required safety technology. Only certified and industry proven safety sensors are used. The furnaces are controlled by a fail-safe PLC control system (S7-300F/ safety controller).

- Certified safety concept
- Automation package (see additional equipment above)
- Redundant gas inlet valves for hydrogen
- Monitored pre-pressures of all process gases
- Bypass for safe purging of furnace chamber with inert gas
- Pressure-monitored emergency flooding with automated solenoid valve opening
- Electric or gas-heated exhaust gas torch for H₂ post-combustion
- Atmospheric operation: H₂-purging of process reactor starting from room temperature at controlled over pressure (50 mbar relative)

Additional equipment

- Partial pressure operation: H₂ flushing at underpressure in the process reactor starting from 750 °C furnace chamber temperature
- Retort in the process chamber for debinding under hydrogen

Process Box for Debinding in Inert Gas

Certain processes require charges to be debinded in non-flammable protective or reactive gases. For these processes we fundamentally recommend a hot-wall retort furnace (see models NR... or SR...). These furnaces can ensure that the formation of condensation will be avoided as thoroughly as possible.

If there is no way to avoid the escape of small amounts of residual binder during the process, even in the VHT furnace, the furnace should be designed to meet this contingency.

The furnace chamber is equipped with an additional process box that has a direct outlet to the exhaust gas torch through which the exhaust gas can be directly vented. This system enables a substantial reduction in the amount of furnace chamber contamination caused by the exhaust gases generated during debinding.

Depending on the exhaust gas composition the exhaust gas line can be designed to include various options.

- Exhaust gas torch for burning off the exhaust gas
- Condensation trap for separating out binding agents
- Exhaust gas post-treatment, depending on the process, via scrubbers
- Heated exhaust gas outlet to avoid condensation deposits in the exhaust gas line



VHT 08/16 MO with hydrogen extension package as automatic version

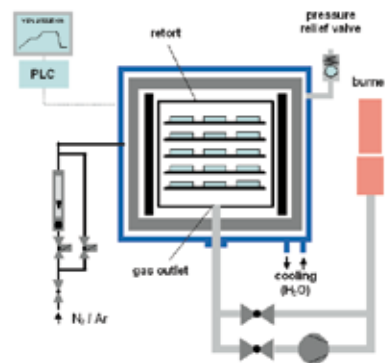

VHT gas supply diagram, debinding and sintering

Model	Tmax °C	Inner dimensions in mm			Volume in l	Outer dimensions in mm			Connected load kW ⁵	Electrical connection*	Weight in kg	Material heater/ insulation
		w	d	h		W	D	H				
VHT 8/..-GR	1800	170	240	200	8	1250 (800) ¹	1100	2000	27	3-phase ²	1200	Graphite/graphite felt
VHT 40/..-GR	or	300	450	300	40	1600	2100	2300	83/103 ³	3-phase	2000	Graphite/graphite felt
VHT 70/..-GR	2200	375	500	375	70	1700	2500	2400	105/125 ³	3-phase	2400	Graphite/graphite felt
VHT 100/..-GR		450	550	450	100	1900	2600	2500	135/155 ³	3-phase	2800	Graphite/graphite felt
VHT 8/..-MO	1200	170	240	200	8	1250 (800) ¹	1100	2700	15/34 ⁴	3-phase ²	1200	Molybdenum
VHT 40/..-MO	or	300	450	300	40	1600	2600	2300	50/110 ⁴	3-phase	3000	Molybdenum
VHT 70/..-MO	1600	375	500	375	70	1700	2800	2400	70/140 ⁴	3-phase	3500	Molybdenum
VHT 100/..-MO		450	550	450	100	1900	3000	2500	90/180 ⁴	3-phase	4000	Molybdenum
VHT 8/18-W	1800	170	240	200	8	1250 (800) ¹	1100	2700	50	3-phase ²	1700	Tungsten/molybdenum
VHT 40/18-W	1800	300	450	300	40	1600	2600	2300	130	3-phase	3500	Tungsten/molybdenum
VHT 70/18-W	1800	375	500	375	70	1700	2800	2400	160	3-phase	4000	Tungsten/molybdenum
VHT 100/18-W	1800	450	550	450	100	1900	3000	2500	210	3-phase	4500	Tungsten/molybdenum
VHT 8/18-KE	1800	170	240	200	8	1250 (800) ¹	1100	2000	12	3-phase ²	1200	MoSi ₂ /ceramic fiber
VHT 40/18-KE	1800	300	450	300	40	1600	2100	2300	30	3-phase	2000	MoSi ₂ /ceramic fiber
VHT 70/18-KE	1800	375	500	375	70	1700	2500	2400	55	3-phase	2400	MoSi ₂ /ceramic fiber
VHT 100/18-KE	1800	450	550	450	100	1900	2600	2500	85	3-phase	2800	MoSi ₂ /ceramic fiber

¹With the switching system unit removed

²Heating only between two phases

³1800 °C/2200 °C

*Please see page 61 for more information about supply voltage
⁴1200 °C/1600 °C

⁵For operation under hydrogen a higher power rating has to be considered

Lift-Bottom-Retort Furnace up to 2400 °C for Production



LBVHT 600/24 GR



LBVHT 250/18 WO with tungsten heating chamber

LBVHT 100/16 - LBVHT 600/24

The LBVHT product line with lift-bottom specification are especially suitable for production processes which require either protective or reaction gas atmosphere or a vacuum. The basic performance specifications of these models are similar to the VHT models. Their size and design with electro-hydraulically driven table facilitate charging during production. The furnaces are available in various sizes and designs. Similar like the VHT models, these furnaces can be equipped with different heating concepts.



LBVHT with graphite heating chamber

- Standard furnace sizes between 100 and 600 liters
- Designed as lift-bottom retort furnace with electro-hydraulically driven table for easy and well-arranged charging
- Prepared to carry heavy charge weights
- Different heating concepts using
 - Graphite heating chamber up to Tmax 2400 °C
 - Molybdenum heating chamber up to Tmax 1600 °C
 - Tungsten heating chamber up to Tmax 1800 °C
- Frame structure filled with textured stainless steel sheets
- Standard design with gassing system for non-flammable protective or reaction gases
- Automatic gas supply system which also allows for operation with several process gases as additional equipment
- Gas supply systems for operating with hydrogen or other flammable reaction gases incl. safety package as additional equipment
- Switchgear and control box as well as gassing system integrated into the furnace housing
- Further product characteristics of the standard furnace as well as possible additional equipment can be found in the description of the VHT furnaces from Page 52

Model	Tmax °C	Model	Tmax °C	Model	Tmax °C	Inner dimensions in mm		Volume in l	Electrical connection*
						Ø	h		
LBVHT 100/16-MO	1600	LBVHT 100/18-WO	1800	LBVHT 100/24-GR	2400	450	700	100	3-phase
LBVHT 250/16-MO	1600	LBVHT 250/18-WO	1800	LBVHT 250/24-GR	2400	600	900	250	3-phase
LBVHT 600/16-MO	1600	LBVHT 600/18-WO	1800	LBVHT 600/24-GR	2400	800	1200	600	3-phase

*Please see page 61 for more information about supply voltage

Pit-Type Cold-Wall Retort Furnaces up to 2400 °C or up to 3000 °C

SVHT 2/24-W - SVHT 9/30-GR

Compared with the VHT models (page 52), the furnaces of the SVHT product line offer improved performance data with regard to achievable vacuum and maximum temperature. Due to the design as pit-type furnace with tungsten heating, processes up to max. 2400 °C even in high vacuum can be implemented with models of the SVHT.-W product line. Models of the SVHT.-GR product line with graphite heating, also in pit-type design, can be operated in an inert gas atmosphere even up to max. 3000 °C.

- Standard sizes with a furnace chamber of 2 or 9 liters
- Designed as pit-type furnace, charged from above
- Frame construction with inserted sheets of textured stainless steel
- Dual shell water-cooled stainless steel container
- Manual operation of process gas and vacuum functions
- Manual gas supply for non-flammable process gas
- A step in front of the furnace for an ergonomic charging height
- Retort lid with gas-charged shock absorbers
- Controls and switchgear as well as gas supply integrated in furnace housing
- Further standard product characteristics see description for standard design of VHT models page 52



SVHT 9/24-W with tungsten heating

Heating options

SVHT ..-GR

- Applicable for processes:
 - under protective or reactive gases or in the vacuum up to 2200 °C
 - under inert gases (argon, helium) up to 3000 °C
- Max. vacuum up to 10⁻³ mbar depending on the type of pump used
- Heating: graphite heating elements in cylindrical arrangement
- Insulation: graphite felt insulation
- Temperature measurement by means of an optical pyrometer



Cylindrical retort with tungsten heating

SVHT ..-W

- Applicable for processes under protective or reaction gases or in vacuum up to 2400 °C
- Max. vacuum up to 10⁻⁵ mbar depending on the type of pump used
- Heating: cylindrical tungsten heating module
- Insulation: tungsten and molybdenum radiant plates
- Temperature measurement with optical pyrometer



Graphite heating module

Additional equipment such as automatic process gas control or design for the operation with flammable gases incl. safety system see VHT models page 52.

Model	Tmax °C	Working chamber dimensions Ø x h in mm	Useful volume in l	Outer dimensions in mm			Connected load KW	Electrical connection*
				W	D	H		
SVHT 2/24-W	2400	150 x 150	2,5	1400	2500	2100	55	3-phase
SVHT 9/24-W	2400	230 x 230	9,5	1500	2750	2100	95	3-phase
SVHT 2/30-GR	3000	150 x 150	2,5	1400	2500	2100	55	3-phase
SVHT 9/30-GR	3000	230 x 230	9,5	1500	2750	2100	95	3-phase

*Please see page 61 for more information about supply voltage



Water-cooling controls

Float-Glass Test Kiln with Wire Heating

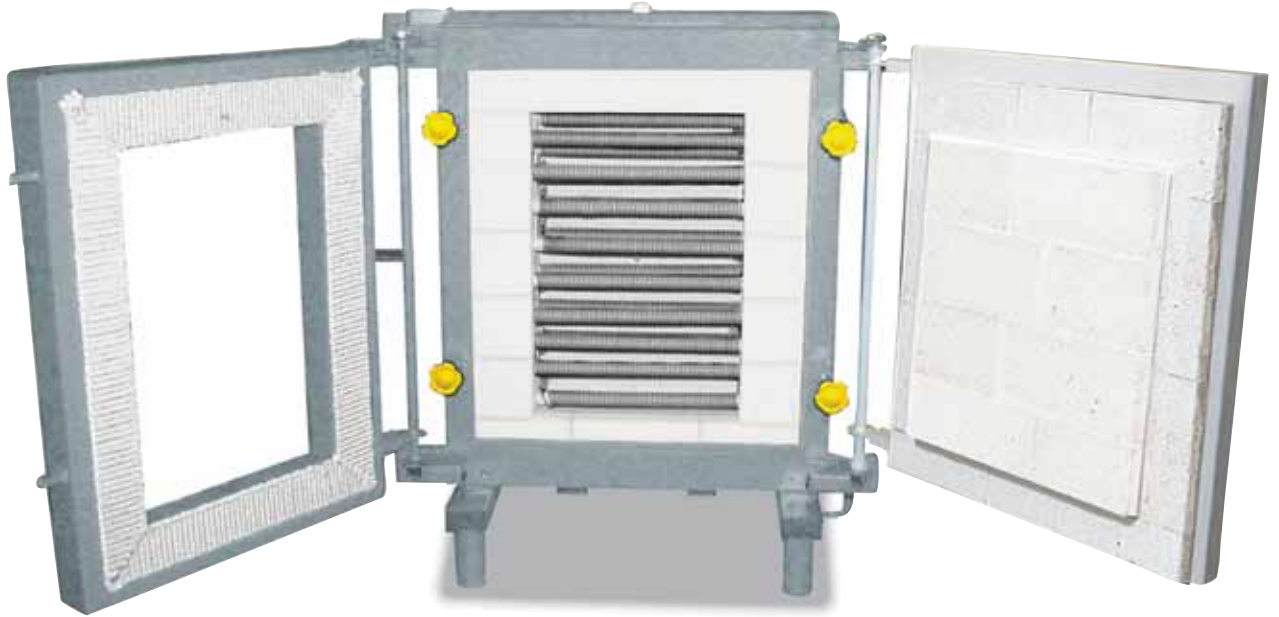

N 40/14

This kiln was designed to test different types of glass plates such as fire protection glass. In addition to the kiln door, there is a second frame which can be swung in front of the inner chamber into which the test plate is placed. This door is fixed with a special mechanism. The kiln chamber is flat and is heated by element coils supported on ceramic tubes mounted only on the back wall so that the heat radiates directly onto the glass surface. The kiln achieves exceptionally short cycle times due to the very small chamber volume and high power input.

Model	Tmax °C	Inner dimensions in mm			Volume in l	Outer dimensions in mm			Connected load kW	Electrical connection*	Weight in kg
		w	d	h		W	D	H			
N 40/14	1400	400	150	600	36	1000	600	1800	36.0	3-phase	250

*Please see page 61 for more information about supply voltage

Laboratory Melting Furnace SC 8 with SiC Rod Heating



Laboratory melting furnace SC 8 with SiC rod heating for use with a customer crucible



Two-Side heating with SiC rods

Model SC 8 was specially developed for melting glass in the laboratory. A customer crucible is entered into the furnace from the top. Glass is molten in the crucible. Heating is realized from two sides with powerful SiC rods. With this heating method a maximum furnace temperature of 1500 °C can be achieved. The very effective, multi-layer insulation with long-life lightweight refractory bricks inside the chamber guarantees low outside temperatures even if the furnace is in continuously used.

Model	Tmax °C	Inner dimensions in mm			Volume in l	Outer dimensions in mm			Connected load kW	Electrical connection*	Weight in kg
		w	d	h		W	D	H			
SC 8	1500	200	150	250	8	840	715	730	30	3-phase	290

*Please see page 61 for more information about supply voltage

Fast-Firing Decoring Furnaces with Infrared Heating



IR 500/90 with alternating table system for firing transfer prints

IR 500/90 - IR 1000/90

These fast-firing decoring furnaces with infrared heating are especially suitable for decal firing of glass or ceramics at working temperatures up to 900 °C. The furnace is equipped with two manually movable tables on castors for easy handling. Both tables and the furnace chamber are insulated with fiber materials. With the fiber insulation in combination with the infrared heating, which provides for a fast surface heating, the furnace achieves particularly short process cycles.

Depending on the charge type the tables may be charged in several layers what allows for an optimal use of the available space. The charge surface with applied decal should face towards the heating elements which are positioned in the roof. While one charged table is positioned in the furnace the other table can already be charged outside the furnace. If the charge permits, the table with still warm charge can be driven out of the furnace and the other table is pushed into the furnace to use the residual energy.

To vent the exhaust gases generated during decoring firing, the furnace is equipped with a motor-driven exhaust gas flap which can be activated via the controls. The stainless steel exhaust hood which is positioned above the motor-driven flap will be connected to customer's ductwork.

- Infrared heating elements in the roof with reflectors installed on each table
- Insulation made of non-classified fiber materials provides for fast process cycles
- Process times of hardly three hours from cold to cold possible, depending on the charge and the working temperature
- Alternating table system on castors, very easy to move
- Motorized exhaust-gas flap on top of the furnace with stainless steel exhaust hood
- Easy-to-operate controls



Infrared heating from the top



Glassware to be decorated

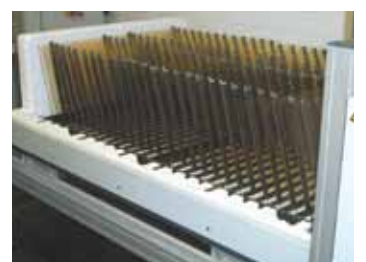

Charging trolley for disc coating

Model	Tmax °C	Inner dimensions in mm			Volume in l	Outer dimensions in mm			Connected load kW	Electrical connection*	Weight in kg
		w	d	h		W	D	H			
IR 500/90	900	1600	900	350	500	6000	1400	1300	36	3phase	1100
IR 1000/90	900	3200	900	350	1000	12000	1400	1300	72	3phase	2000

*Please see page 61 for more information about supply voltage

Temperature Uniformity and System Accuracy

Temperature uniformity is defined as the maximum temperature deviation in the useful space of the furnace. There is a general difference between the furnace chamber and the useful space. The furnace chamber is the total volume available in the furnace. The useful space is smaller than the furnace chamber and describes the volume which can be used for charging.

Specification of Temperature Uniformity in ΔK in the Standard Furnace

In the standard design the temperature uniformity is specified as the relative, maximum deviation from a defined reference temperature within the useful space in the empty furnace at dwell time. Temperature uniformity is defined as ΔT in K. If, for example, a standard temperature uniformity of ΔT 10 K at 750 °C is specified, it means that the actual temperature in the furnace can vary between 740 °C and 750 °C or between 750 °C and 760 °C.

Specification of the Temperature Uniformity in +/- °C as Additional Feature

If an absolute temperature uniformity at a reference temperature or at a defined reference temperature range is required, the furnace must be calibrated appropriately. If, for example, a temperature uniformity of +/- 5 °C at a set temperature of 750 °C is required, it means that measured temperatures may range from a minimum of 745 °C to a maximum of 755 °C in the useful space.

System Accuracy

Tolerances may occur not only in the useful space, they also exist with respect to the thermocouple and in the controls. If an absolute temperature uniformity in +/- °C at a defined set temperature or within a defined reference temperature range is required, the following measures have to be taken:

- Measurement of total temperature deviation of the measurement line from the controls to the thermocouple
- Measurement of temperature uniformity within the useful space at the reference temperature or within the reference temperature range
- If necessary, an offset is set at the controls to adjust the displayed temperature at the controller to the real temperature in the furnace
- Documentation of the measurement results in a protocol

Temperature Uniformity in the Useful Space incl. Protocol

In standard furnaces a temperature uniformity is guaranteed as ΔT without measurement of temperature uniformity. However, as additional feature, a temperature uniformity measurement at a reference temperature in the useful space compliant with DIN 17052-1 can be ordered. Depending on the furnace model, a holding frame which is equivalent in size to the charge space is inserted into the furnace. This frame holds thermocouples at 11 defined measurement positions. The measurement of the temperature uniformity is performed at a reference temperature specified by the customer at a pre-defined dwell time. If necessary, different reference temperatures or a defined reference working temperature range can also be calibrated.

For the configuration of furnace and control system to meet specific industry standards such as AMS 2750 E, CQI-9, or FDA, Naberm offers adapted solutions. See our catalog „Thermal Process Technology“



Precision of the controls, e.g. +/- 2 °C

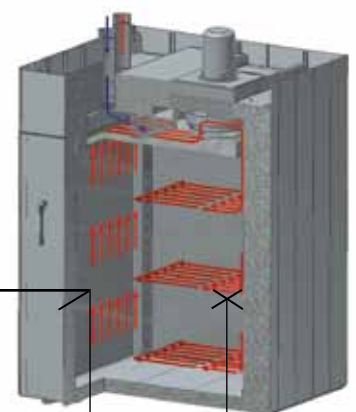

Deviation of thermocouple, e.g. +/- 1.5 °C

Deviation from measuring point to the average temperature in the useful chamber +/- 3 °C

The system accuracy is defined by adding the tolerances of the controls, the thermocouple and the useful space

Process Control and Documentation

Nabertherm has many years of experience in the design and construction of both standard and custom control system. All controls are remarkable for their ease of use and even in the basic version have a wide variety of functions.

Standard Controllers

Our extensive line of standard controllers satisfies most customer requirements. Based on the specific furnace model, the controller regulates the furnace temperature reliably. The standard controllers are developed and fabricated within the Nabertherm group. When developing controllers, our focus is on ease of use. From a technical standpoint, these devices are custom-fit for each furnace model or the associated application. From the simple controller with an adjustable temperature to the control unit with freely configurable control parameters, stored programs, PID microprocessor control with self-diagnosis system and a computer interface, we have a solution to meet your requirements.

Assignment of Standard Controllers to Furnace Families

	W 1000/... A - W 8300/... A	KTR	TR	N 15/65 HA	N 30/65 HA - N 500/85 HA	W 1000/G - W 10000/14	WHTC	N 100/G - N 2200/14	N 100 - N 2200/H	LH	H	HC	HT	HTC	HFL	HTB	HT... LB or LT	TS, TSB	N 7/H - N 17/HR	N 31/H - N 641/13	GF	GFM	GW	HG	NFA	NRA ... H ₂ version	NRA ... IDB version	SRA, SR	VHT	LBVHT	SVHT	N 40/14	SC 8	IR		
Catalog page	4	8	10	12	12	14	17	18	18	20	22	24	26	29	30	31	32	38	39	39	40	42	44	46	48	50	50	51	52	56	57	58	58	59		
Controller																																				
P 300	●	○			○	●		●	○	○									○	○	●	●			●											
P 310						● ¹			○	○			● ¹	● ¹	● ¹		● ¹			○	○						●							●		
C 6/3208		○			○																															
R 6			●																																	
B 130									●																											
B 150		●			●					●																										
B 180			○	○	●																															
P 330			○	○	○							●																								
C 40																																				
C 280									○																											
3504	○	○ ³	○		○											●		●		○					○			○							●	
H 700/PLC							● ¹		○				● ¹	● ¹	● ¹		● ¹		○					○			●		●	●						
H 1700/PLC	○	○			○	○		○				○												○		○	○	○	○	○	○	○	○	○	○	○
H 3700/PLC	○	○			○	○		○				○												○		○	○	○	○	○	○	○	○	○	○	○
NCC	○	○			○	○		○				○												○		○	○	○	○	○	○	○	○	○	○	○

Functionality of the Standard Controllers

	P 300	P 310	R 6	B 130	B 150	B 180	P 330	C 40	C 280	3504	H 700	H 1700	H 3700
Number of programs	9	9	1	2	1	1	9	9	9	1-50	10	10	10
Segments	40	40	1	3	2	2	40	18	3	bis 500	20	20	20
Extra functions (e.g. fan or autom. flaps)	2 ²	2 ²					2	2	2	2-8	○	6	8
Maximum number of control zones	1	1	1	1	1	1	1	1	1	2 ²	○	8	8
Graphic color display											5,7"	5,7"	12"
Status messages in clear text	●	●		●	●	●	●	●	●	●	●	●	●
Start time configurable (e.g. to use night power rates)	●	●		●	●	●	●	●	●	●	●	●	●
Operating hour counter	●	●		●	●	●	●	●	●	●	●	●	●
Auto tune	●	●		●	●	●	●	●	●	●	●	●	●
Program entry in steps of 1 °C or 1 min.	●	●	●	●	●	●	●	●	●	●	●	●	●
Keypad lock				●	●				●				
Skip-button for segment jump	●	●					●				○	●	●
Drive of manual zone regulation		●											
Interface for MV software	○	○		○	○	○	●	●	○				
USB extension module for recording of process data on an USB flash drive with NTLog see page 62	○	○		○	○	○	○	○	○			○	○
Programmable power outlet							●						
kWh meter	●	●		●	●	●	●	●	●				
Real-time clock							●	●			●	●	●
Bath control/charge control									○		○	○	○
Data entry via touchpanel											●	●	●
Data input via number pad	●	●					●	●	●				●

● Standard

○ Option

¹ standard controller depending on design

² as an extra feature in ovens with air circulation

³ incl. MV-software package incl. Eurotherm 2404

Mains Voltages for Nabertherm Furnaces

1-phase: all furnaces are available for mains voltages from 110 V - 240 V at 50 or 60 Hz.

3-phase: all furnaces are available for mains voltages from 200 V - 240 V or 380 V - 480 V, at 50 or 60 Hz.



PC for HiProSystems control in a separate cabinet



H 1700 with colored, tabular depiction of the data



H 3700 with colored graphic presentation of data



Temperature recorder

HiProSystems Control and Documentation

This professional control system for single and multi-zone furnaces is based on Siemens hardware and can be adapted and upgraded extensively. HiProSystems control is used when more than two process-dependent functions, such as exhaust air flaps, cooling fans, automatic movements, etc., have to be handled during a cycle, when furnaces with more than one zone have to be controlled, when special documentation of each batch is required and when remote telediagnostic service is required. It is flexible and is easily tailored to your process or documentation needs.

Alternative User Interfaces

Touch panel H 700

This basic panel accommodates most basic needs and is very easy to use.

Touch panel H 1700

Firing cycle data and the extra functions activated are clearly displayed in a table. Messages appear as text.

Touch panel H 3700

All functions and process data are stored and displayed in easy to read charts. The data can be exported through various interfaces (Ethernet TCP/IP, MPI, Profibus) to a local PC or your company network for further processing. A CF card also gives the opportunity for data storage and transfer to a PC with a card reader.

For Control, Visualisation and Documentation

Nabertherm Control Center NCC

Upgrading the HiProSystems-Control individually into an NCC provides for additional interfaces, operating documentation, and service benefits in particular for controlling furnace groups including charge beyond the furnace itself (quenching tank, cooling station etc.):

- Recommended for heat treatment processes with extensive requirements in respect to documentation e.g. for metals, technical ceramics or in the medicine field
- Software can be used also in accordance with the AMS 2750 E (NADCAP)
- Documentation according to the requirements of Food and Drug Administration (FDA), Part 11, EGV 1642/03 possible
- Charge data can be read in via barcodes
- Interface for connection to existing Enterprise Database systems (e.g. SAP, Oracle)
- Connection to mobile phone network for alarm message transmission via SMS
- Control from various locations over the network
- Calibration of each measuring point for a specific temperature possible
- Extendable for calibration of a polygonal line with up to 18 temperatures per measuring point for use at different temperatures e.g. for AMS 2750 E applications

For Documentation

Nabertherm Documentation Center NDC and data recording via NT Log

If the process data of the HiProSystems control unit only need to be recorded, this can be done using a personal computer (PC) with the high-performance NDC software. The data are documented, forgery-proof, and can be evaluated both in the form of a table or a chart. Individual charge data can be entered by the customer and are archived together with the process data. A low-cost alternative which can be used is the NT Log package. The data is recorded on a USB stick during the firing. After the heat treatment has been completed, the recorded value can be read out on the PC with the free analysis software.

Temperature Recorder

Besides the documentation via the software which is connected to the controls, Nabertherm offers different temperature recorders which can be used with respect to the application.

	Model 6100e	Model 6100a	Model 6180a
Data input using touch panel	x	x	x
Size of colour display in inch	5,5	5,5	12,1
Number of thermocouple inputs	3	18	48
Data read-out via USB-stick	x	x	x
Input of charge data	x	x	x
Evaluation software included	x	x	x
Applicable for TUS-measurements acc. to AMS 2750 E			x

Controltherm MV Software for Control, Visualisation and Documentation

Documentation and reproducibility gain increased attention with steadily rising quality standards. The powerful Nabertherm software Controltherm MV provides for an optimum solution for the control and documentation of one or more furnaces as well as charge data on basis of Nabertherm controllers.

In the basic version one furnace can be connected to the MV-software. The system can be extended to four, eight or even 16 multi-zone controlled furnaces. Up to 400 different heat treatment programs can be stored. The process will be documented and filed. Process data can be read-out graphically or in table format. A data transfer to MS-Excel is also possible.

For furnaces which are not controlled via a Nabertherm controller, the furnace temperature can be documented with the MV-software. We deliver an extension package as optional equipment. With respect to the individual version, three, six or even nine independent thermocouples can be connected. Independent of the control system, the values of each thermocouple will be read-out and evaluated by the MV-software.

Features

- Simple installation without specific knowledge
- All Nabertherm controllers with interface connectable
- Manipulation protected storage of temperature curves of up to one, four, eight or 16 furnaces (also multizone-controlled), depending on the version of MV-software
- Redundant storage on a network server possible
- Programming, archiving and printing of programs and graphics
- Free input of descriptive charge data text with comfortable search function
- Data exportable into Excel format for further evaluation
- Start/stop of the controller from the local PC (only with Nabertherm controllers mit interface)
- Selectable languages: German, English, French, Italian or Spanish
- 400 additional programs storable (only with Nabertherm controllers with interface)



Controltherm MV Software for Control, Visualisation and Documentation



Data input in table format if used together with Nabertherm controllers

Extension Package II for Connection of one Additional Temperature Measuring Point, Independent of the Controller

- Connection of an independent thermocouple, type K or S with display of the measured temperature on the included controller C 6 D, e.g. for documentation of charge temperature
- Conversion and transmission of measured data to the MV-software
- For data evaluation, please see MV-software features

Extension Package II for Connection Three, Six or Nine Temperature Measuring Points, Independent of the Controller

- Connection of three thermocouples, type K, S, N or B to the supplied connection box
- Extendable to two or three connection boxes for up to nine temperature measuring points
- Conversion and transmission of measured data to the MV-software
- For data evaluation, please see MV-software features

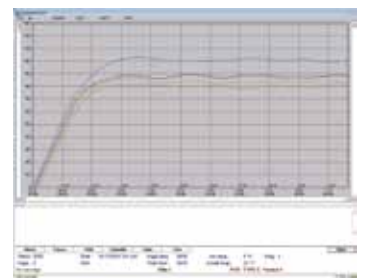

Graphical display of set and actual temperature curve



Extendable for connection of up to 16 furnaces

The whole World of Nabertherm: www.nabertherm.com

Please visit our website

www.nabertherm.com and find out all you want to know about us - and especially about our products.

Besides news and our current calendar of trade fairs, there is also the opportunity to get in touch directly with your local sales office or nearest dealer worldwide.

Professional Solutions for:

- Arts & Crafts
- Glass
- Advanced Materials
- Laboratory
- Dental
- Thermal Process Technology for Metals, Plastics and Surface Finishing
- Foundry



Headquarters:

Nabertherm GmbH
Bahnhofstr. 20
28865 Lilienthal, Germany

contact@nabertherm.de
Phone: (+49) 4298 922-0
Fax: (+49) 4298 922-129

Sales and Service Subsidiaries

Nabertherm Ltd. (Shanghai)
150 Lane, No. 158 Pingbei Road, Minhang District
201109 Shanghai, China

contact@nabertherm-cn.com
Phone: (+86) 21 6490 2960
Fax: (+86) 21 6490 3107

Nabertherm SAS
51 Rue de Presles
93531 Aubervilliers, France

contact@nabertherm.fr
Phone: (+33) 1 5356 1800
Fax: (+33) 1 5356 1809

Nabertherm Italia
via Trento N° 17
50139 Florence, Italy

contact@nabertherm.it
Phone: (+39) 348 3820278
Fax: (+39) 055 480835

Nabertherm Schweiz AG
Batterieweg 6
4614 Högendorf, Switzerland

contact@nabertherm.ch
Phone: (+41) 62 209 6070
Fax: (+41) 62 209 6071

Nabertherm Ltd.
Vigo Place, Aldridge
West Midlands WS9 8YB, United Kingdom

contact@nabertherm.co.uk
Phone: (+44) 1922 455 521
Fax: (+44) 1922 455 277

Nabertherm Inc.
54 Read's Way
New Castle, DE 19720, USA

contact@nabertherm-usa.com
Phone: (+1) 302 322 3665
Fax: (+1) 302 322 3215

Nabertherm España
c/Martí i Julià, 8 Bajos 7a
08940 Cornellà de Llobregat, Spain

contact@nabertherm.es
Phone: (+34) 93 474 47 16
Fax: (+34) 93 474 53 03